

TG700
TV Signal Generator Platform
Specifications and Performance Verification
Technical Reference



077-0137-01

TG700
TV Signal Generator Platform
Specifications and Performance Verification
Technical Reference

This document applies to firmware version 5.2 and above.

www.tektronix.com

077-0137-01



Copyright © Tektronix. All rights reserved. Licensed software products are owned by Tektronix or its subsidiaries or suppliers, and are protected by national copyright laws and international treaty provisions.

Tektronix products are covered by U.S. and foreign patents, issued and pending. Information in this publication supersedes that in all previously published material. Specifications and price change privileges reserved.

TEKTRONIX and TEK are registered trademarks of Tektronix, Inc.

Contacting Tektronix

Tektronix, Inc.
14200 SW Karl Braun Drive
P.O. Box 500
Beaverton, OR 97077
USA

For product information, sales, service, and technical support:

- In North America, call 1-800-833-9200.
- Worldwide, visit www.tektronix.com to find contacts in your area.

Warranty

Tektronix warrants that this product will be free from defects in materials and workmanship for a period of one (1) year from the date of shipment. If any such product proves defective during this warranty period, Tektronix, at its option, either will repair the defective product without charge for parts and labor, or will provide a replacement in exchange for the defective product. Parts, modules and replacement products used by Tektronix for warranty work may be new or reconditioned to like new performance. All replaced parts, modules and products become the property of Tektronix.

In order to obtain service under this warranty, Customer must notify Tektronix of the defect before the expiration of the warranty period and make suitable arrangements for the performance of service. Customer shall be responsible for packaging and shipping the defective product to the service center designated by Tektronix, with shipping charges prepaid. Tektronix shall pay for the return of the product to Customer if the shipment is to a location within the country in which the Tektronix service center is located. Customer shall be responsible for paying all shipping charges, duties, taxes, and any other charges for products returned to any other locations.

This warranty shall not apply to any defect, failure or damage caused by improper use or improper or inadequate maintenance and care. Tektronix shall not be obligated to furnish service under this warranty a) to repair damage resulting from attempts by personnel other than Tektronix representatives to install, repair or service the product; b) to repair damage resulting from improper use or connection to incompatible equipment; c) to repair any damage or malfunction caused by the use of non-Tektronix supplies; or d) to service a product that has been modified or integrated with other products when the effect of such modification or integration increases the time or difficulty of servicing the product.

THIS WARRANTY IS GIVEN BY TEKTRONIX WITH RESPECT TO THE PRODUCT IN LIEU OF ANY OTHER WARRANTIES, EXPRESS OR IMPLIED. TEKTRONIX AND ITS VENDORS DISCLAIM ANY IMPLIED WARRANTIES OF MERCHANTABILITY OR FITNESS FOR A PARTICULAR PURPOSE. TEKTRONIX' RESPONSIBILITY TO REPAIR OR REPLACE DEFECTIVE PRODUCTS IS THE SOLE AND EXCLUSIVE REMEDY PROVIDED TO THE CUSTOMER FOR BREACH OF THIS WARRANTY. TEKTRONIX AND ITS VENDORS WILL NOT BE LIABLE FOR ANY INDIRECT, SPECIAL, INCIDENTAL, OR CONSEQUENTIAL DAMAGES IRRESPECTIVE OF WHETHER TEKTRONIX OR THE VENDOR HAS ADVANCE NOTICE OF THE POSSIBILITY OF SUCH DAMAGES.

[W2 – 15AUG04]

Table of Contents

General Safety Summary	vi
Environmental Considerations	viii
Preface	ix
Products	ix
Related User Documents	x
Specifications	1
TG700 Mainframe Specifications	1
AG7 Specifications	4
AGL7 Specifications	5
ATG7 Specifications	7
AVG7 Specifications	12
AWVG7 Specifications	13
BG7 Specifications	15
DVG7 Specifications	16
GPS7 Specifications	18
HD3G7 Specifications	23
HDLG7 Specifications	27
HDVG7 Specifications	33
Performance Verification	35
Performance Verification Preparation	35
TG700 Mainframe Performance Verification	36
AG7 Module Performance Verification	38
AGL7 Module Performance Verification	42
ATG7 Module Performance Verification	57
AVG7 Module Performance Verification	71
AWVG7 Module Performance Verification	91
BG7 Module Performance Verification	104
DVG7 Module Performance Verification	111
GPS7 Module Performance Verification	117
HD3G7 Module Performance Verification	142
HDLG7 Module Performance Verification	156
HDVG7 Module Performance Verification	159

List of Figures

Figure 1: TG700 dimensions	3
Figure 2: Equipment connection for verifying subcarrier frequency	37
Figure 3: Initial equipment connection for verifying the serial digital audio outputs.....	39
Figure 4: Second equipment connection for verifying the serial digital audio outputs	41
Figure 5: Equipment connection for verifying the 48 kHz clock output	42
Figure 6: Equipment connections for verifying the genlock function	45
Figure 7: Equipment connection for verifying the trilevel sync outputs	49
Figure 8: Equipment connection for verifying burst and sync amplitude	53
Figure 9: Equipment connection for verifying subcarrier frequency	54
Figure 10: Location of the J040 and J960 connectors	55
Figure 11: Equipment connection for verifying the 48 kHz clock output.....	56
Figure 12: Equipment connection for verifying pulse amplitude	60
Figure 13: Equipment connection for verifying burst and sync amplitude	63
Figure 14: Equipment connection for verifying the DC offset and amplitude error	75
Figure 15: Equipment connection for verifying the channel-to-channel delay	77
Figure 16: Equipment connection for verifying the frequency response	80
Figure 17: Verifying the signal amplitudes from 500 kHz to 5 MHz.....	82
Figure 18: Equipment connection for verifying the line time distortion	83
Figure 19: Equipment connection for checking the color bars signal	90
Figure 20: Equipment connection for verifying the DC offset and amplitude error	94
Figure 21: Equipment connection for verifying the frequency response	97
Figure 22: Verifying the signal amplitudes	98
Figure 23: Equipment connection for verifying the field time distortion	99
Figure 24: Equipment connection for checking the color bars signal	103
Figure 25: Equipment connection for verifying the trilevel sync outputs.....	106
Figure 26: Equipment connection for verifying burst and sync amplitude	109
Figure 27: Equipment connection for verifying the serial digital outputs.....	112
Figure 28: Equipment connections for verifying the serial digital video outputs	158
Figure 29: Equipment connections for verifying the serial digital outputs	162
Figure 30: Equipment connection for verifying the output level and eye pattern.....	167
Figure 31: Example of eye pattern for an acceptable output signal.....	167

List of Tables

Table 1: Electrical characteristics	1
Table 2: Environmental characteristics	2
Table 3: Mechanical characteristics	2
Table 4: AES/EBU serial digital audio outputs	4
Table 5: SILENCE output	4
Table 6: 48 kHz CLOCK output	4
Table 7: Output timing	5
Table 8: Environmental characteristics	5
Table 9: Electrical characteristics, Genlock function	5
Table 10: Black burst signal and HDTV trilevel sync signal outputs	6
Table 11: Word clock signal output ¹	7
Table 12: Environmental characteristics	7
Table 13: Black burst and timing pulse outputs	7
Table 14: Color bars signal output	8
Table 15: Test signal output	9
Table 16: Common outputs characteristics	11
Table 17: Environmental characteristics	11
Table 18: Output channels	12
Table 19: Common output characteristics	12
Table 20: Environmental characteristics	13
Table 21: Output channels	14
Table 22: Common output characteristics	14
Table 23: Environmental characteristics	14
Table 24: Black burst and HDTV trilevel sync outputs	15
Table 25: Color bars and black burst with field ID outputs (option CB)	16
Table 26: Environmental characteristics	16
Table 27: Serial digital video signal outputs	17
Table 28: Serial digital black signal outputs (Option BK only)	17
Table 29: Embedded audio	17
Table 30: Environmental characteristics	18
Table 31: Black burst and sine outputs	18
Table 32: Antenna input	19
Table 33: Timebase	20
Table 34: LTC outputs	22
Table 35: GPI signals	22
Table 36: Environmental characteristics	23
Table 37: 3 Gb/s serial video signal outputs	23
Table 38: Trigger / clock outputs	24

Table 39: HD SDI Input	24
Table 40: Video signal content.....	25
Table 41: Synthesizer generated 3 Gb/s test signals.....	25
Table 42: Embedded audio and ancillary data.....	25
Table 43: Supported input and output formats (SMPTE 274M to SMPTE 425M standards; Level A mapping structure 1 and Level B fast progressive)	26
Table 44: Mechanical characteristics.....	26
Table 45: Environmental characteristics.....	27
Table 46: 4:2:2 serial digital video signal input.....	27
Table 47: Dual link serial video outputs	28
Table 48: Video signal content.....	28
Table 49: Synthesizer generated HD test signals	28
Table 50: Synthesizer generated projector test patterns	29
Table 51: Embedded audio and ancillary data.....	31
Table 52: Supported input and output formats (SMPTE 274M to SMPTE 372M standards).....	31
Table 53: Mechanical characteristics.....	32
Table 54: Environmental characteristics.....	32
Table 55: Serial digital video signal outputs	33
Table 56: Serial digital black signal outputs (Option BK only)	33
Table 57: Embedded audio	34
Table 58: Environmental characteristics.....	34
Table 59: Required Equipment for TG700 mainframe performance verification	36
Table 60: TG700 mainframe test record	36
Table 61: Required equipment for AG7 performance verification.....	38
Table 62: AG7 test record	38
Table 63: Required equipment for AGL7 performance verification	43
Table 64: AGL7 test record	43
Table 65: Required equipment for ATG7 performance verification	57
Table 66: ATG7 test record.....	57
Table 67: Required equipment for AVG7 performance verification	71
Table 68: AVG7 test record	72
Table 69: Required equipment for AWVG7 performance verification	91
Table 70: AWVG7 test record.....	91
Table 71: Required equipment for BG7 performance verification	104
Table 72: BG7 test record	104
Table 73: Required equipment for DVG7 performance verification.....	111
Table 74: DVG7 test record	111
Table 75: Required equipment for GPS7 performance verification.....	117
Table 76: GPS7 test record	119
Table 77: Required equipment for HD3G7 performance verification	142
Table 78: HD3G7 test record.....	144

Table 79: Required equipment for HDLG7 performance verification	156
Table 80: HDLG7 test record	156
Table 81: Required equipment for HDVG7 performance verification.....	159
Table 82: HDVG7 test record	160

General Safety Summary

Review the following safety precautions to avoid injury and prevent damage to this product or any products connected to it.

To avoid potential hazards, use this product only as specified.

Only qualified personnel should perform service procedures.

To Avoid Fire or Personal Injury

Use Proper Power Cord. Use only the power cord specified for this product and certified for the country of use.

Ground the Product. This product is grounded through the grounding conductor of the power cord. To avoid electric shock, the grounding conductor must be connected to earth ground. Before making connections to the input or output terminals of the product, ensure that the product is properly grounded.

Observe All Terminal Ratings. To avoid fire or shock hazard, observe all ratings and markings on the product. Consult the product manual for further ratings information before making connections to the product.

Power Disconnect. The power cord disconnects the product from the power source. Do not block the power cord; it must remain accessible to the user at all times.

Do Not Operate Without Covers. Do not operate this product with covers or panels removed.

Do Not Operate With Suspected Failures. If you suspect that there is damage to this product, have it inspected by qualified service personnel.

Avoid Exposed Circuitry. Do not touch exposed connections and components when power is present.

Wear Eye Protection. Wear eye protection if exposure to high-intensity rays or laser radiation exists.

Do Not Operate in Wet/Damp Conditions.

Do Not Operate in an Explosive Atmosphere.

Keep Product Surfaces Clean and Dry.

Provide Proper Ventilation. Refer to the manual's installation instructions for details on installing the product so it has proper ventilation.

Terms in this Manual These terms may appear in this manual:



WARNING. *Warning statements identify conditions or practices that could result in injury or loss of life.*



CAUTION. *Caution statements identify conditions or practices that could result in damage to this product or other property.*

- DANGER indicates an injury hazard immediately accessible as you read the marking.
- WARNING indicates an injury hazard not immediately accessible as you read the marking.
- CAUTION indicates a hazard to property including the product.



CAUTION
Refer to Manual



WARNING
High Voltage



Double
Insulated



Protective Ground
(Earth) Terminal



Not suitable for
connection to
the public telecom-
munications network

Environmental Considerations

This section provides information about the environmental impact of the product.

Product End-of-Life Handling

Observe the following guidelines when recycling an instrument or component:

Equipment Recycling. Production of this equipment required the extraction and use of natural resources. The equipment may contain substances that could be harmful to the environment or human health if improperly handled at the product's end of life. In order to avoid release of such substances into the environment and to reduce the use of natural resources, we encourage you to recycle this product in an appropriate system that will ensure that most of the materials are reused or recycled appropriately.



This symbol indicates that this product complies with the European Union's requirements according to Directive 2002/96/EC on waste electrical and electronic equipment (WEEE). For information about recycling options, check the Support/Service section of the Tektronix Web site (www.tektronix.com).

Restriction of Hazardous Substances

This product has been classified as Monitoring and Control equipment, and is outside the scope of the 2002/95/EC RoHS Directive.

Preface

This manual describes the specifications and performance verification procedures for the TG700 TV Signal Generator Platform and related modules. It is divided into two sections: Specifications and Performance Verification. The first section provides physical and electrical specifications. The latter section provides performance verification procedures.

Products

The information in this manual applies to the following products:

- TG700 TV Generator Platform
- AG7 Audio Generator Module
- AGL7 Analog Genlock Module
- ATG7 Analog Test Generator Module
- AVG7 Analog Video Generator Module
- AWVG7 Analog Wideband Video Generator Module
- BG7 Black Generator Module
- DVG7 Digital Video Generator Module
- GPS7 GPS Synchronization and Timecode Module
- HD3G7 HD 3 Gb/s SDI Video Generator
- HDLG7 HD Dual Link Generator Module
- HDVG7 HDTV Digital Video Generator Module

Related User Documents

Following is a list of documents that contain user information about the TG700 and its related modules:

- The *TG700 TV Signal Generator Platform User Manual* (Tektronix part number 071-1970-XX English, 071-1971-XX Japanese) describes how to install and operate the mainframe and related modules.
- The *TG700 TV Signal Generator Platform Programmer Manual* (Tektronix part number 077-0139-XX) provides programming information for the mainframe and related modules.
- The *TG700TV Signal Generator Platform PC Tools Technical Reference* (Tektronix part number 077-0138-XX) describes how to use certain PC tools available for the mainframe and related modules.
- The *TG700 TV Signal Generator Platform Service Manual* (Tektronix part number 077-0230-XX) describes how to service the TG700 mainframe to the module level (such as circuit boards and fuses) and provides general information about servicing generator modules. Specific service information for a module is located in its service manual. Service manuals are optional and must be ordered separately.

Specifications

The information in this section provides electrical, mechanical, and environmental specifications for the TG700 mainframe and related modules.

The performance requirements listed in the electrical characteristics portion of these specifications apply over an ambient temperature range of 0 °C to +50 °C. The rated accuracies are valid when the instrument is calibrated at an ambient temperature range of +20 °C to +30 °C, after a warm-up time of 20 minutes.

TG700 Mainframe Specifications

The following tables list certification and compliance information, and the electrical, environmental, and mechanical characteristics of the TG700 mainframe.

Electrical Characteristics The following table lists the electrical characteristics of the TG700 mainframe.

Table 1: Electrical characteristics

Characteristic	Performance requirements	Reference information
The number of modules that can be installed	Maximum 4	Only a limited number of some modules can be installed in a TG700 mainframe: AGL7, GPS7– Only one (1) of these modules can be installed in the mainframe at a time. When one is installed, it must be installed in slot 1 only AWVG7, HD3G7, and HDVG7 – Only a combined total of two (2) of these modules can be installed in the mainframe at the same time when the HDVG7 module has a rear-panel fan. If the HDVG7 module does not have a rear-panel fan, then a combined total of three (3) of these modules can be installed.
Clock, stability	< 1 ppm/year	
AC power source	Rating voltage	100 V to 240 VAC
	Voltage range	85 V to 250 VAC
	Frequency range	48 Hz to 63 Hz
	Maximum power	100 W
	Maximum current	1.2 A
Heat Dissipation, maximum power		100 W maximum. Maximum line current is 1.2 A rms at 50 Hz
Surge current		≤ 40 A peak for equal or less than 5 line cycles, after the instrument has been turned off for at least 30 seconds.

Table 1: Electrical characteristics (cont.)

Characteristic	Performance requirements	Reference information
Clearance	Side	5 cm
	Rear	5 cm

Environmental Characteristics

The following table lists the environmental characteristics of the TG700 mainframe.

Table 2: Environmental characteristics

Characteristic	Description
Temperature	Operating 0 °C to +50 °C
	Nonoperating -20 °C to +60 °C
Relative Humidity	Operating 20% to 80% (No condensation) Maximum wet-bulb temperature 29.4 °C
	Nonoperating 5% to 90% (No condensation) Maximum wet-bulb temperature 40.0 °C
Altitude	Operating To 4.5 km (15,000 feet) Maximum operating temperature decreases 1 °C each 300 m above 1.5 km.
	Nonoperating To 15 km (50,000 feet)
Vibration	Operating 2.65 m/s ² (0.27 G _{rms}), 5 Hz to 500 Hz, 10 min, three axes
	Nonoperating 22.3 m/s ² (2.28 G _{rms}), 5 Hz to 500 Hz, 10 min, three axes
Shock, Nonoperating	294 m/s ² (30 G), half-sine, 11 ms duration

Mechanical Characteristics

The following table lists the mechanical characteristics of the TG700 mainframe.

Table 3: Mechanical characteristics

Characteristic	Description
Dimensions	Height 44 mm
	Width 483 mm
	Depth 559 mm
Weight ¹ , net	Approximately 5.5 kg (mainframe only, without rack rail)

¹ Weight of the TG700 will vary depending on the number and type of generator or other modules installed.

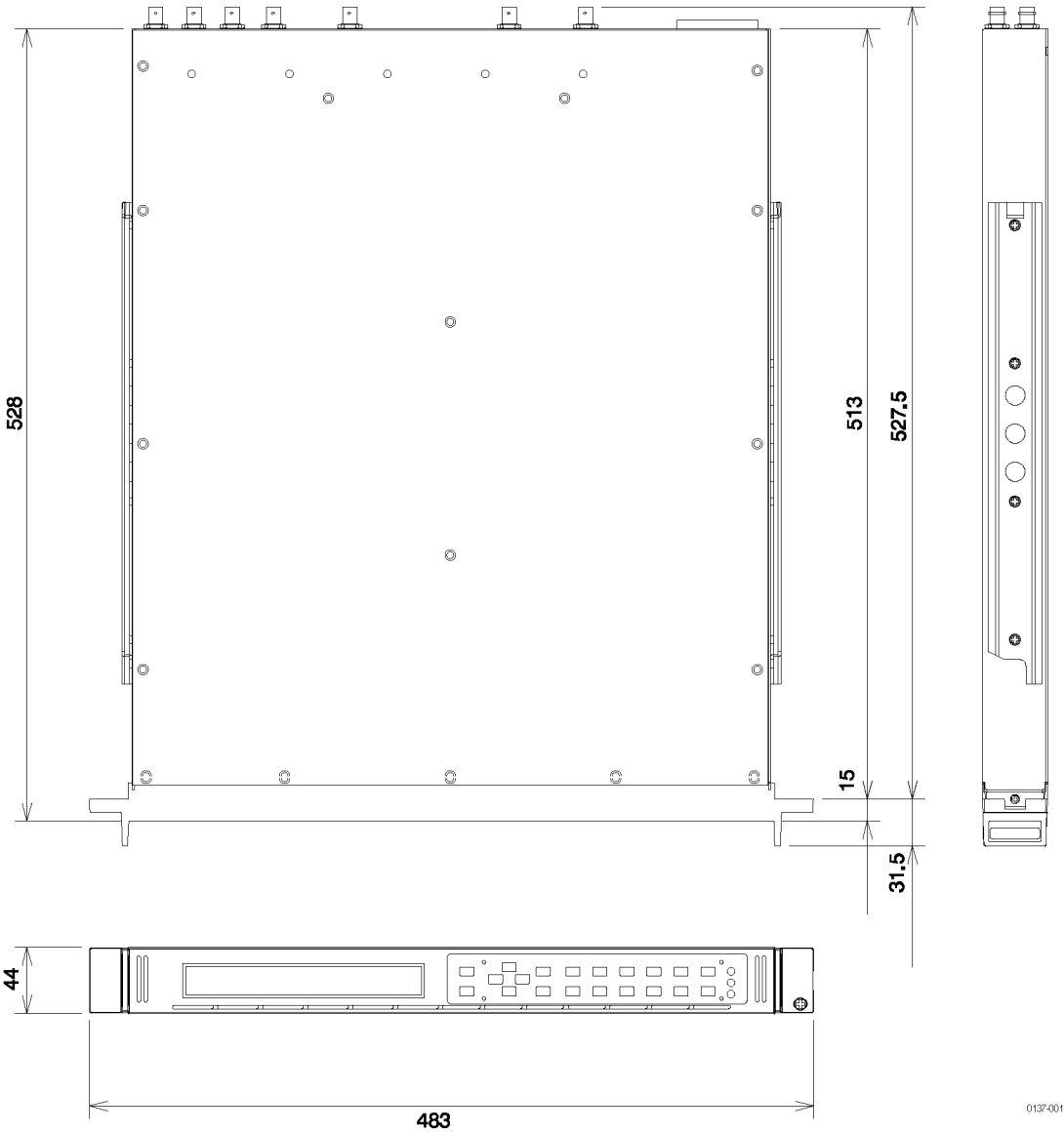

Figure 1: TG700 dimensions

AG7 Specifications

The following tables list the electrical and environmental characteristics of the AG7 Audio Generator module.

Electrical Characteristics The following tables in this section list the electrical characteristics of the AG7 module.

Table 4: AES/EBU serial digital audio outputs

Characteristic		Performance requirements	Reference information
Connector		4	BNC
Number of channels		8	1+2, 3+4, 5+6, and 7+8
Quantized resolution		20 or 24 bits	User selectable
Audio tone	Frequency	Silence to 20 kHz	31 discrete settings
	Level	0 to -60 dBFS in 1 dB steps	
Pre-emphasis			None
Output level		1 ± 0.1 V	Measured across 75 Ω .
Required receiver termination		75 $\Omega \pm 10\%$	
Jitter		Within $\pm 20\%$	
Rise and fall times		Between 30 ns and 44 ns	Measured from the 10% to 90% points.

Table 5: SILENCE output

Characteristic		Performance requirements	Reference information
SILENCE			Same signal as AES/EBU Serial Digital Audio "Silence".
Connector			BNC
Output level		1 ± 0.1 V	Measured across 75 Ω .
Required receiver termination		75 $\Omega \pm 10\%$	
Jitter		Within $\pm 20\%$	
Rise and fall times		Between 30 ns and 44 ns	Measured from the 10% to 90% points.

Table 6: 48 kHz CLOCK output

Characteristic		Performance requirements	Reference information
48 kHz CLOCK			Reference Clock for AES/EBU Serial Digital Audio.
Connector			BNC
Output level			User selectable by the internal jumper. Level 1 is selected at the factory.
	Level 1	CMOS compatible	High > 2.1 V, Low < 0.8 V
	Level 2	1 ± 0.1 V	Measured across 75 Ω .

Table 7: Output timing

Characteristic	Performance requirements	Reference information
Range	± 160 ms	Relative to the frame reset signal.
Resolution	1 μ s	

Environmental Characteristics

The following table lists the environmental characteristics of the AG7 module.

Table 8: Environmental characteristics

Characteristic	Description	
Temperature	Operating	0 °C to +50 °C
	Nonoperating	-20 °C to +60 °C
Relative Humidity	Operating	20% to 80% (No condensation); Maximum wet-bulb temperature 29.4 °C
	Nonoperating	5% to 90% (No condensation); Maximum wet-bulb temperature 40.0 °C
Altitude	Operating	To 4.5 km (15,000 feet) Maximum operating temperature decreases 1 °C each 300 m above 1.5 km.
	Nonoperating	To 15 km (50,000 feet)
Vibration	Operating	3.04 m/s ² (0.31 G _{rms}), 5 Hz to 500 Hz, 10 min, three axes
	Nonoperating	23.3 m/s ² (2.38 G _{rms}), 5 Hz to 500 Hz, 10 min, three axes
Shock, nonoperating	294 m/s ² (30 G), half-sine, 11 ms duration	

AGL7 Specifications

The following tables list the electrical and environmental characteristics of the AGL7 Genlock module.

Electrical Characteristics

The following tables in this section list the electrical characteristics of the AGL7 module.

Table 9: Electrical characteristics, Genlock function

Characteristic	Performance requirements	Reference information
Input configuration	75 Ω loop through	REF inputs
	75 Ω terminated	CW input
Return loss	> 40 dB	5 MHz
	> 35 dB	5 MHz to 30 MHz
Input requirements	NTSC/PAL black burst or Trilevel sync	

Table 9: Electrical characteristics, Genlock function (cont.)

Characteristic		Performance requirements	Reference information
Reference inputs	Amplitude	± 6 dB	
	S/N ratio	> 40 dB	
	SCH phase	$\pm 40^\circ$	
CW input		1, 3.58, 4.43, 5, or 10 MHz CW	The CW input connector can be configured to output a 48 kHz word clock signal by changing internal cabling.
	Input range	1 to 2.5 Vp-p	
Pull-in range		Subcarrier frequency ± 15 Hz	
Jitter	Burst lock	$< 0.5^\circ$	
	Sync lock	< 1 ns	

Table 10: Black burst signal and HDTV trilevel sync signal outputs

Characteristic		Performance requirements	Reference information
Connector		BNC	
Number of outputs		3	BLACK1, BLACK2, and BLACK3
Configuration	BLACK1	Black burst	BLACK1 always generates Black burst.
	BLACK2	Black burst or Trilevel sync	When the trilevel sync signal is selected, the signal to be the same signal as BLACK 3 is output.
	BLACK3	Black burst or Trilevel sync	When the black burst is selected, the signal to be the same signal as BLACK 2 is output.
Burst amplitude accuracy		$\pm 2\%$	
Sync amplitude accuracy		$\pm 2\%$	
Sync rise time	NTSC		140 ns
	PAL		250 ns
Return loss		> 30 dB to 30 MHz	
Timing offset	Range	Full color frame	
	Resolution	$< 0.5^\circ$ of sub carrier	

Table 11: Word clock signal output ¹

Characteristic	Performance requirements	Reference information
Connector	BNC	Same connector as CW
Frequency	48 kHz	
Level	CMOS compatible	Without termination
Impedance	75 $\Omega \pm 10\%$	

¹ This output is enabled when the configuration of the CW connector is changed.

Environmental Characteristics

The following table lists the environmental characteristics of the AGL7 module.

Table 12: Environmental characteristics

Characteristic	Description	
Temperature	Operating	0 °C to +50 °C
	Non-operating	-20 °C to +60 °C
Relative Humidity	Operating	20% to 80% (No condensation); Maximum wet-bulb temperature 29.4 °C
	Non-operating	5% to 90% (No condensation); Maximum wet-bulb temperature 40.0 °C
Altitude	Operating	To 4.5 km (15,000 feet) Maximum operating temperature decreases 1 °C each 300 m above 1.5 km.
	Non-operating	To 15 km (50,000 feet)
Vibration	Operating	3.04 m/s ² (0.31 G _{rms}), 5 Hz to 500 Hz, 10 min, three axes
	Non-operating	23.3 m/s ² (2.38 G _{rms}), 5 Hz to 500 Hz, 10 min, three axes
Shock, non-operating	294 m/s ² (30 G), half-sine, 11 ms duration	

ATG7 Specifications

The following tables list the electrical characteristics and the environmental characteristics of the ATG7 Generator module.

Electrical Characteristics

The following tables in this section list the electrical characteristics of the ATG7 module.

Table 13: Black burst and timing pulse outputs

Characteristic	Performance requirements	Reference information
Connector	BNC	
Number of outputs	2	BLACK 1 and BLACK 2
Output impedance, typical	75 Ω	

Table 13: Black burst and timing pulse outputs (cont.)

Characteristic	Performance requirements		Reference information
Black burst output signals	NTSC and NTSC No Setup		Black Burst Black Burst with Field REF
	PAL		Black Burst Black Burst with No Field REF
Timing pulse output	Amplitude accuracy		1.0± 0.1 V
	Rise time	NTSC and NTSC No Setup	140± 20 ns
		PAL	250± 20 ns
	Output signals		
	NTSC and NTSC No Setup	Composite Sync Composite Blanking Subcarrier H Drive V Drive Field Reference	
	PAL	Composite Sync Subcarrier Composite Blanking H Drive V Drive Field Reference PAL Pulse	

Table 14: Color bars signal output

Characteristic	Performance requirements	Reference information
Connector	BNC	
Number of outputs	1	BARS
Output impedance, typical	75 Ω	

Table 14: Color bars signal output (cont.)

Characteristic	Performance requirements	Reference information
Output signals	NTSC and NTSC No Setup	SMPTE Color Bar 100% Color Bar 75% Color Bar 40% Flat Field Black Burst Black Burst with Field REF Other 1 Other 2
	PAL	100% Color Bar 75% Color Bar 100% Color Bar Over Red 75% Color Bar Over Red 40% Flat Field Black Burst Black Burst No Field REF Other 1 Other 2
ID text	Maximum 18 characters	
Luminance amplitude accuracy	$\pm 1\%$	Measured at 700 mV.
Chrominance to luminance gain	$\pm 2\%$	Chrominance is measured at red portion of the 75% Color Bar Over Red signal.

Table 15: Test signal output

Characteristic	Performance requirements	Reference information
Connector	BNC	
Number of outputs	1	SIGNAL
Output impedance, typical	75 Ω	

Table 15: Test signal output (cont.)

Characteristic	Performance requirements	Reference information
Output signals	NTSC and NTSC No Setup formats	100%, 75%, SMPTE Color Bars 5 Step, 10 Step, Modulated 5 Step, Modulated Pedestal, Modulated Ramp, Ramp, Shallow Ramp 0% Flat Field (NTSC format only), 10% Flat Field, 40% Flat field, 50% Flat Field, 100% Flat Field, Field Square Wave, Black Burst, Black Burst with Field Reference 100% Multiburst, 60% Multiburst, Multipulse 100% Sweep, 60% Sweep, Chroma Response 100% Red Field, 75% Red Field, 2 Level Ped. & Pluge, 4 Level Ped. & Pluge, Convergence, Gray Window, White Window, Safe Area, Monitor Setup Window 2T Pulse Bar, Sin X/X FCC Composite, FCC Multiburst, NTC7 Combination, NTC7 Composite, Test Matrix, SNG Color Bars
	PAL format	100% Colour Bars, 75% Colour Bars, 100% Colour Bars Over Red, 75% Colour Bars Over Red 5 Step, 10 Step, Modulated 5 Step, Modulated Pedestal, Modulated Ramp, Ramp, Shallow Ramp 40% Flat field, 50% Flat Field, 100% Flat Field, Field Square Wave, Black Burst, Black Burst with No Field Reference, Field Square Wave 100% Multiburst, Multipulse 100% Sweep, 60% Sweep 100% Red Field, 75% Red Field, 2 Level Ped. & Pluge, 4 Level Ped. & Pluge, Convergence, Grey Window, White Window, Safe Area, Monitor Setup Matrix 2T Pulse Bar, Sin X/X CCIR 17, CCIR 18, CCIR 330, CCIR 331, UKITS 1, UKITS 2, UK 1 Line ITS, ITS Matrix
ID text	Maximum 18 characters	
Luminance amplitude accuracy	± 1%	Measured at 700 mV.
Chrominance to luminance gain	± 1%	
Frequency response	± 1%	To 5 MHz
Chrominance to luminance delay	≤ 10 ns	Measured at 500 kHz and 4.43 MHz.

Table 15: Test signal output (cont.)

Characteristic	Performance requirements	Reference information
Linearity	< 1%	< 0.5% (typical); measured at 5 step signal.
Differential gain error	< 0.5%	Measured at modulated 5 step signal.
Differential phase error	< 0.5°	Measured at modulated 5 step signal.
Field tilt	< 0.5%	
Line tilt	< 0.5%	

Table 16: Common outputs characteristics

Characteristic	Performance requirements	Reference information
Return loss	≥ 36 dB	To 6 MHz
Burst amplitude accuracy	± 2%	
Sync amplitude accuracy	± 2%	
Blanking level	0 mV ± 50 mV	
SCH phase accuracy	0° ± 5°	
Timing offset		
	Range	Full color frame
	Resolution	54 MHz clock resolution ≈18.5 ns

Environmental Characteristics

The following table lists the environmental characteristics of the ATG7 module.

Table 17: Environmental characteristics

Characteristic		Description
Temperature	Operating	0 °C to +50 °C
	Nonoperating	-20 °C to +60 °C
Relative Humidity	Operating	20% to 80% (No condensation); Maximum wet-bulb temperature 29.4 °C
	Nonoperating	5% to 90% (No condensation); Maximum wet-bulb temperature 40.0 °C
Altitude	Operating	To 4.5 km (15,000 feet) Maximum operating temperature decreases 1 °C each 300 m above 1.5 km.
	Nonoperating	To 15 km (50,000 feet)
Vibration	Operating	3.04 m/s ² (0.31 G _{rms}), 5 Hz to 500 Hz, 10 min, three axes
	Nonoperating	23.3 m/s ² (2.38 G _{rms}), 5 Hz to 500 Hz, 10 min, three axes
Shock, nonoperating		294 m/s ² (30 G), half-sine, 11 ms duration

AVG7 Specifications

The following tables list the electrical and environmental characteristics of the AVG7 Generator module.

Electrical Characteristics The following tables in this section list the electrical characteristics of the AVG7 module.

Table 18: Output channels

Characteristic		Performance requirements	Reference information
Channel 1 (CH 1)	Number of outputs	2	
	Output signals	Y, G, or composite	Each component of a composite signal can be turned On or Off using the VIDEO submenu.
Channel 2 (CH 2)	Number of outputs	2	
	Output signals	B-Y, Pb, B, C, or composite	Each component of a composite signal can be turned On or Off using the VIDEO submenu.
Channel 3 (CH 3)	Number of outputs	2	
	Output signals	R-Y, Pr, R, or composite	Each component of a composite signal can be turned On or Off using the VIDEO submenu.

Table 19: Common output characteristics

Characteristic		Performance requirements	Reference information
Amplitude error	Absolute amplitude	$\leq 1\%$	Measured at 700 mV.
	Channel gain matching	$\leq 0.5\%$	Measured at 700 mV, relative to CH 1.
	Chrominance to luminance gain	$\leq 1\%$	Measured at 700 mV, relative to 500 kHz.
Delay error	Chrominance to luminance delay, typical		≤ 2.5 ns on a composite output.
	Channel to channel delay	≤ 1 ns	Relative to CH 1
	Group delay, typical		≤ 5 ns to 5 MHz
	SCH Phase error, typical		≤ 1.25 ns ($\pm 1.6^\circ$ at 3.58 MHz and (plus-minus) 2° at 4.43 MHz)

Table 19: Common output characteristics (cont.)

Characteristic	Performance requirements	Reference information
Frequency response	Flat within 0.5% peak from 0.5 MHz to 5 MHz.	Typically $\leq 5\%$ to 8 MHz at 700 mV, measured with a 1 m coax cable and peak detector.
Line time distortion	$\leq 0.5\%$	Measured with FCC composite signal.
Field time distortion	$\leq 0.5\%$	Measured with field square wave.
K factor 2T5 pulse	$\leq 0.5\%$	
Pulse/bar ratio, typical		1:1 within 0.5% with 2T5 pulse and bar signal.
DC offset	≤ 10 mV	
Differential gain	$\leq 0.5\%$	
Differential phase	$\leq 0.5^\circ$	
Return loss	≥ 40 dB to 6 MHz	

Environmental Characteristics

The following table lists the environmental characteristics of the AVG7 module.

Table 20: Environmental characteristics

Characteristic		Description
Temperature	Operating	0 °C to +50 °C
	Non-operating	-20 °C to +60 °C
Relative Humidity	Operating	20% to 80% (No condensation); Maximum wet-bulb temperature 29.4 °C
	Non-operating	5% to 90% (No condensation); Maximum wet-bulb temperature 40.0 °C
Altitude	Operating	To 4.5 km (15,000 feet) Maximum operating temperature decreases 1 °C each 300 m above 1.5 km.
	Non-operating	To 15 km (50,000 feet)
Vibration	Operating	2.65 m/s ² (0.27 G _{rms}), 5 Hz to 500 Hz, 10 min, three axes
	Non-operating	22.36 m/s ² (2.28 G _{rms}), 5 Hz to 500 Hz, 10 min, three axes
Shock, non-operating		588 m/s ² (60 G), half-sine, 11 ms duration

AWVG7 Specifications

The following tables list the electrical and environmental characteristics of the AWVG7 Generator module.

Electrical Characteristics

The following tables in this section list the electrical characteristics of the AWVG7 module.

Table 21: Output channels

Characteristic		Performance requirements	Reference information
Channel 1 (CH 1)	Number of outputs	2	
	Output signals	Y or G	
Channel 2 (CH 2)	Number of outputs	2	
	Output signals	Pb or B	
Channel 3 (CH 3)	Number of outputs	2	
	Output signals	Pr or R	

Table 22: Common output characteristics

Characteristic		Performance requirements	Reference information
Amplitude error	Absolute amplitude	≤ 1%	Measured at 700 mV.
	Channel gain matching	≤ 0.5%	Measured at 700 mV, relative to CH 1.
Delay error	Channel to channel delay, typical		≤ 1 ns; relative to CH 1
	Group delay, typical		≤ 3 ns to 20 MHz ≤ 5 ns to 30 MHz
Frequency response		± 1% to 20 MHz ± 2% to 28 MHz ± 3% to 30 MHz	Measured with a 1 m coax cable and peak detector.
Line tilt		≤ 0.5%	Measured with 100% Flat Field test signal.
Field tilt		≤ 0.5%	Measured with 100% Flat Field test signal.
Pulse/bar ratio			1:1 within 0.5% with 2T5 pulse and bar signal.
DC offset		≤ 10 mV	
Return loss		≥ 35 dB to 30 MHz	

Environmental Characteristics

The following table lists the electrical characteristics of the AWVG7 module.

Table 23: Environmental characteristics

Characteristic	Description	
Temperature	Operating	0 °C to +50 °C
	Non-operating	-20 °C to +60 °C
Relative Humidity	Operating	20% to 80% (No condensation); Maximum wet-bulb temperature 29.4 °C
	Non-operating	5% to 90% (No condensation); Maximum wet-bulb temperature 40.0 °C

Table 23: Environmental characteristics (cont.)

Characteristic		Description
Altitude	Operating	To 4.5 km (15 000 feet) Maximum operating temperature decreases 1 °C each 300 m above 1.5 km.
	Non-operating	To 15 km (50 000 feet)
Vibration	Operating	2.65 m/s ² (0.27 G _{rms}), 5 Hz to 500 Hz, 10 min, three axes
	Non-operating	22.36 m/s ² (2.28 G _{rms}), 5 Hz to 500 Hz, 10 min, three axes
Shock, non-operating		588 m/s ² (60 G), half-sine, 11 ms duration

BG7 Specifications

The following tables list the electrical characteristics and the environmental characteristics of the BG7 Generator module.

Electrical Characteristics

The following tables in this section list the electrical characteristics of the BG7 module.

Table 24: Black burst and HDTV trilevel sync outputs

Characteristic	Performance requirements	Reference information
Connector	BNC	
Number of outputs	4	BLACK1, BLACK2, BLACK3, and BLACK4
Output impedance, typical	75 Ω	
Return loss	≥ 30 dB	To 30 MHz
Burst amplitude accuracy	± 2%	NTSC and PAL
Sync amplitude accuracy		
NTSC/PAL	± 2%	
TriLevel	± 2%	
Blanking level	0± 50 mV	
SCH phase accuracy	0°± 5°	
Timing offset		
Range	Full color frame	
Resolution		
NTSC/PAL	1/54 μs	≈18.5 ns
TriLevel	1/74.25 μs or 1/(74.25/1.001) ms	≈13.9 ns

Table 25: Color bars and black burst with field ID outputs (option CB)

Characteristic	Performance requirements	Reference information
Color bars signals	NTSC	100% Color Bars, 75% Color Bars, SMPTE Color Bars, 40% Flat Field, SNG Color Bar, Monitor Setup Matrix
	NTSC No Setup	100% Color Bars, 75% Color Bars, SMPTE Color Bars, 40 % Flat Field, SNG Color Bar, Monitor Setup Matrix
	PAL	100% Color Bars, 75% Color Bars, 100% Color Bars Over Red, 75% Color Bars Over Red, 40% Flat Field, SNG Color Bars, 4 Level Pluge, Monitor Setup Matrix
Black burst with field ID		
Luminance amplitude accuracy	± 1%	Measured at 700 mV.
Chrominance to luminance gain	± 2%	Chrominance is measured at red portion of the 75% Color Bars Over Red signal.

Environmental Characteristics

The following table lists the environmental characteristics of the BG7 module.

Table 26: Environmental characteristics

Characteristic	Description
Temperature	Operating 0 °C to +50 °C
	Nonoperating -20 °C to +60 °C
Relative Humidity	Operating 20% to 80% (No condensation); Maximum wet-bulb temperature 29.4 °C
	Nonoperating 5% to 90% (No condensation); Maximum wet-bulb temperature 40.0 °C
Altitude	Operating To 4.5 km (15,000 feet) Maximum operating temperature decreases 1 °C each 300 m above 1.5 km.
	Nonoperating To 15 km (50,000 feet)
Vibration	Operating 3.04 m/s ² (0.31 G _{rms}), 5 Hz to 500 Hz, 10 min, three axes
	Nonoperating 23.3 m/s ² (2.38 G _{rms}), 5 Hz to 500 Hz, 10 min, three axes
Shock, nonoperating	294 m/s ² (30 G), half-sine, 11 ms duration

DVG7 Specifications

The following tables list the electrical and environmental characteristics of the DVG7 Generator module.

Electrical Characteristics

The following tables in this section list the electrical characteristic of the DVG7 module.

Table 27: Serial digital video signal outputs

Characteristic	Performance requirements	Reference information
Connector	BNC	
Number of output	2	SIGNAL 1 and SIGNAL 2
Bit Rate	143 Mbps	
	270 Mbps	
Signal amplitude, typical	800 mV± 10%	
Rise and fall times, typical	0.4 ns to 1.5 ns	20% to 80%
Jitter, typical	≤ 0.2 Ulp-p	For all jitter frequencies above 10 Hz.
Return loss	> 15 dB	5 MHz to 270 MHz

Table 28: Serial digital black signal outputs (Option BK only)

Characteristic	Performance requirements	Reference information
Connector	BNC	
Number of output	2	BLACK 1 and BLACK 2
Bit Rate	143 Mbps	
	270 Mbps	
Signal amplitude, typical	800 mV± 10%	
Rise and fall times, typical	0.4 ns to 1.5 ns	20% to 80%
Jitter, typical	≤ 0.2 Ulp-p	For all jitter frequencies above 10 Hz.
Return loss	> 15 dB	5 MHz to 270 MHz

Table 29: Embedded audio

Characteristic	Performance requirements	Reference information
Number of channels	16 channels in 4 groups; 8 AES/EBU audio pairs	
Audio tones	Frequency	Silence to 20 kHz; 31 discrete settings
	Level	-60 to 0 dBFS in 1 dB steps
	Pre-emphasis	Emphasis status bits can be inserted.

Environmental Characteristics

The following table lists the environmental characteristics of the DVG7 module.

Table 30: Environmental characteristics

Characteristic	Description	
Temperature	Operating	0 °C to +50 °C
	Non-operating	-20 °C to +60 °C
Relative Humidity	Operating	20% to 80% (No condensation); Maximum wet-bulb temperature 29.4 °C
	Non-operating	5% to 90% (No condensation); Maximum wet-bulb temperature 40.0 °C
Altitude	Operating	To 4.5 km (15,000 feet) Maximum operating temperature decreases 1 °C each 300 m above 1.5 km.
	Non-operating	To 15 km (50,000 feet)
Vibration	Operating	3.04 m/s ² (0.31 G _{rms}), 5 Hz to 500 Hz, 10 min, three axes
	Non-operating	23.3 m/s ² (2.38 G _{rms}), 5 Hz to 500 Hz, 10 min, three axes
Shock, non-operating	294 m/s ² (30 G), half-sine, 11 ms duration	

GPS7 Specifications

The following tables list the electrical and environmental characteristics of the GPS7 GPS Synchronization and Timecode module.

Electrical Characteristics The following tables in this section list the electrical characteristics of the GPS7 module.

Table 31: Black burst and sine outputs

Characteristic	Performance requirements	Reference information
Connector	BNC	
Number of outputs	3	All can be black, or Black #3 can be configured as 10 MHz sine wave. Black #2 can be configured to blank during certain errors to trigger an ECO change-over.
Formats	Each output is individually selectable between Bi-level NTSC with or without field ref, NTSC No setup with or without field pulse, PAL with or without field ref, or Tri-level 1080i59.94, 1080i60, 1080i50, 720p59.94, 720p60, 720p50, 1080p24, 1080p23.98, 1080p29.97, 1080p30, 1080sf24, 1080sf23.98, 1080p25	
Standards supported	RS170A, SMPTE RP154, SMPTE318M, EBU N14, SMPTE240M, 274M, 296M, RP211	
Output impedance, typical	75 Ω	
Return loss	40 dB from 300 kHz to 5 MHz, 30 dB to 30 MHz	

Table 31: Black burst and sine outputs (cont.)

Characteristic	Performance requirements	Reference information
Amplitude in cal mode	$\pm 1\%$ on difference between 0 and 700 mV DC levels	
Amplitude	Standard level for selected format $\pm 2\%$	Nominal amplitudes are NTSC -286 mV sync, Pal -300 mV sync, all HD rates ± 300 mV tri-level sync.
Offset	0 ± 50 mV	
Offset in cal mode	0 ± 40 mV	
Bi-Level Sync	NTSC	140 ns
Rise and Fall time (typical)	PAL	250 ns
Tri-Level Sync Rise and Fall time (typical)		50 ns
SCH		± 5 deg for NTSC and PAL
Timing Adjust Composite		Each output individually adjustable over $\pm \frac{1}{2}$ the color frame with 0.5 deg of subcarrier resolution
Timing Adjust HD rates		Each output individually adjustable over $\pm \frac{1}{2}$ the frame with <20 ns resolution
Signal to Noise ratio (typical)		>60 dB RMS noise relative to 700 mV. DC to 20 MHz.
Sine output amplitude		1.5 V _{p-p} $\pm 10\%$

Table 32: Antenna input

Characteristic	Performance requirements	Reference information
Connector	BNC	
Number of inputs	1	
Input impedance (typical)	50 Ω	Internally terminated
Input signal level minimum (typical)	> 18 dB above ambient level	Nominal gain of antenna minus cable loss, so a 35 dB antenna can have 17 dB cable loss at 1.575 GHz
Return Loss (typical)	8 dB at 1575 MHz	Input has a narrow RF filter so reflects most energy not near the GPS signal frequency.
DC Antenna power output voltage (typical)	3.3 or 5 V at nominal load	Sourced on Antenna input. May be enabled or disable. Approximately 12 Ω internal resistance so open circuit voltage is greater. Open circuit voltage is typically 3.8 V and 5.4 V.

Table 32: Antenna input (cont.)

Characteristic	Performance requirements	Reference information
DC Antenna power output current (typical)	55 mA.	
Antenna fault thresholds (typical)	“OPEN” if <10 mA, “SHORT” if > 100 mA. Else “Nominal”	Antenna power state is displayed on UI in GPS7 status screen. Rear LED shows green flashing if open, green steady if nominal, red if shorted, and off if the power is not enabled.

Table 33: Timebase

Characteristic	Performance requirements	Reference information
Reference Modes	User may select Internal or External lock to GPS Reference	“Internal” sets the frequency to nominal. “External” sets the timebase relative to the GPS input and aligns the frames to extrapolate back to the SMPTE Epoch.
Operation when loses lock	User may select Internal or holdover called “Stay Current Frequency”. “Internal” reverts to the nominal frequency as calibrated. “Stay Current Frequency ” holds the last valid frequency from before the input was lost.	
Location Modes	User may select “Fixed” or “Mobile”	“Fixed” stores a well-averaged position and then uses that until set to re-acquire. “Mobile” re-calculates the position continuously and thus has a higher timebase variation
Stability when locked to GPS (typical)	Allan Deviation < 1E-10, measure interval of 1,10 or 100 sec in fixed position mode.	Note that this is for fixed mode and is a function of mainframe oscillator, satellite signal quality from antenna, and GPS7 functionality. For mobile mode, the Allan deviation is about 2E-10.
Accuracy when locked to GPS	±1 part in 10 ⁹ averaged over 30 sec. After 20 min warm up and in fixed mode.	Long term stability is set by the GPS, but short term by the mainframe..
Accuracy in internal mode (typical)	±0.1 ppm after calibration	Note that this is a function of mainframe oscillator and is only valid inside calibration interval.
Accuracy in Holdover Mode (typical)	±10 parts in 10 ⁹ from recent valid lock frequency, Temp change of ±5 °C. ±50 parts in 10 ⁹ for 0 to 50 °C.	Translates to 10 ns of drift per 1 sec that is in holdover mode. This is a function of the mainframe oscillator.
Clean Recovery Holdover Drift	±20 ms	Maximum amount of timebase drift that can be corrected without disruption to video timing.

Table 33: Timebase (cont.)

Characteristic	Performance requirements	Reference information
Clean Recovery Holdover Duration (typical)	20 days, must be in stable temperature environment and have warmed up for 20 minutes before holdover	Length of time that can be in stay current holdover mode and recover without disruption to syncs. Dependant on environment and mainframe oven oscillator stability.
Aging Drift (typical)	<0.2 ppm per year for Internal and Stay Genlock mode at constant temperature	
Timing behavior when locked	Displays "Locked" if within 150 ns of absolute time as detected by GPS signal	
Frame Timing Accuracy in fixed position mode (typical)	Outputs of any two units are typically timed within 150 ns if both have good signal quality and the same cable delay from antenna to instrument	Frames Based on SMPTE 404 / TAI Epoch
Frame Behavior on Relock (typical)	Selectable between Jam Phase, Fast Slew and Stay Legal. In Stay Legal mode, will stay in spec as slew with respect to frequency offset and drift rate spec. If in fast slew or stay legal mode, frames will slew back to the correct alignment via timebase offset without jumping.	Recovery from drift may take a long time if configured for stay legal recovery (approximately 300 sec per line of drift at NTSC or PAL rates).
Timebase offset during Relock (typical)	For stay legal mode, limited to less than ± 0.2 ppm frequency offset, and limited to change less than 0.02 ppm/sec	Fast Slew has limits of ± 5 ppm offset and 0.5 ppm / sec
Time to acquire satellites and achieve specified stability (typical)	2 Minutes on boot up with warm oven, good satellite signal, and known position	Frames may jump on initial lock to establish correct relative positions
Definition of Lock Status Figure of Merit	0 No signal 1 Low signal 2 Acquire Satellites 3 Bad Position 4 Acquire Position 5 Adjust Phase 6 Locked > Signal Quality ≤ 16 7 Locked >> Signal Quality > 16 8 Locked >>> Signal Quality > 26 9 Locked >>>> Signal Quality > 42 10 Locked >>>>> Signal Quality > 68 11 Locked >>>>>> Signal Quality > 110	Note that receiver may take a few minutes to detect and display the signal

Table 34: LTC outputs

Characteristic	Performance requirements	Reference information
Formats	23.98, 24, 25, 30, 30 drop as per SMPTE 12M	
Output Level Accuracy	5 V \pm 10% at max level. Differential into 600 Ω	
Output Level Range	Adjustable from 0.5 to 5 V into 600 Ω	
Output Level Adj Resolution (typical)	0.5 V steps	
Output Rise and Fall Time (typical)	40 μ s	
Output Impedance	30 Ω for each output	
Output load	600 nominal, 150 min	
Timing Adj range	\pm 1 half a frame for selected format	
Timing Adjust Resolution	10 μ s steps	
Timecode Offset Range	24 hrs	
Timecode Offset Resolution	1 frame	

Table 35: GPI signals

Characteristic	Performance requirements	Reference information
Connections	2 open collector outputs and one input with pull-up	
Logical Functions	The function of the input and outputs may be set from the UI	Outputs may be set to assert at a given program time, when unlocked from GPS, or at an adjustable Antenna signal level. Input may be set to reset the program time, assert jam sync, or to reacquire position.
Input High level (typical)	2.4 V min	
Input Low Level (typical)	0.8 V max	
Input Timing (typical)	Inputs valid if detected on three consecutive samples at approximately 16.7 ms SW polling loop. Will always ignore inputs that are asserted for less than 25 ms, and will always detect a pulse asserted more than 75 ms.	
Output Low Voltage (typical)	0.5 V at 100 mA	
Output Max high voltage (typical)	25 Volts max	Outputs internally pulled up to 5 V through 10 k Ω and a diode
Output Max current (typical)	300 mA	
Output Duration (typical)	Signal Alarms asserted as long as the error condition exists. Timer based outputs asserted for the 1 sec that the selected time counter matches the user defined time.	

Environmental Characteristics

The following table lists the environmental characteristics of the GPS7 module.

Table 36: Environmental characteristics

Characteristic		Description
Temperature	Operating	0 °C to +50 °C
	Nonoperating	-20 °C to +60 °C
Relative Humidity	Operating	20% to 80% (No condensation); Maximum wet-bulb temperature 29.4 °C
	Nonoperating	5% to 90% (No condensation); Maximum wet-bulb temperature 40.0 °C
Altitude	Operating	To 4.5 km (15,000 feet) Maximum operating temperature decreases 1 °C each 300 m above 1.5 km.
	Nonoperating	To 15 km (50,000 feet)

HD3G7 Specifications

The following tables list the electrical, mechanical, and environmental characteristics of the HD3G7 HD 3 Gb/s SDI Video Generator module.

Electrical Characteristics

The following tables in this section list the electrical characteristics of the HD3G7 module.

Table 37: 3 Gb/s serial video signal outputs

Characteristic	Performance requirements	Reference information
Connector	75 Ω BNC	
Number of outputs	2	SIGNAL 1 and SIGNAL 2
Format	1080p50, 1080p59.94, and 1080p60 Level A and B	
Output level	800 mVp-p	± 3% on level after ringing has settled 18 to 28° C range Measure on 20 Bit square wave in calibration mode
Output Level Variation with Temperature, typical	± 1% typical for 0 to 50°C	
Rise and fall times	135 ps max. (20% to 80%) measured between runs of at least 3 bits times of constant level	20% to 80%
Jitter, typical (generator mode)	67 ps p-p max.	0.2 UI alignment jitter

Table 37: 3 Gb/s serial video signal outputs (cont.)

Characteristic	Performance requirements	Reference information
Jitter, typical (converter mode)	>3 dB attenuation above 50 Hz, limited by generator jitter floor spec.	Apply video with low-frequency jitter – measure output jitter. Use basic jitter measure to screen
Return loss, typical	≥ 20 dB	5 MHz to 2.5 GHz
	≥ 10 dB	2.5 GHz to 3 GHz
Overshoot, typical	> 5%	
DC shift during 32 μs pathological pattern, typical	> 25 mV	Amount of shift depends on video format. Many 3Gb/s formats will be less than ½ of this.
Signal timing, typical		<p>Signals are nominally timed such that the timing reference point on the serial output is aligned within 0.5 μs of the reference edge of an analog reference signal at the same frame rate. Vertically, the first lines with the broad pulses are aligned.</p> <p>Timing adjust of lines is in terms of the raster image, so for Level B signals, this corresponds to ½ of the time for the multiplexed combination of two lines.</p>

Table 38: Trigger / clock outputs

Characteristic	Performance requirements	Reference information
Connector	50 Ω output	75 Ω BNC connector
Number of outputs	1, configurable as clock, line, or frame	SIGNAL 1 and SIGNAL 2
Output level	720 mV ± 10%	Into 50 Ω
Rise and fall times, typical	≤ 135 ps	20% to 80%
Jitter, typical	≤ 10 ps RMS max	
Return loss, typical	≥ 15 dB	10 MHz to 300 MHz

Table 39: HD SDI Input

Characteristic	Description
Number of inputs	1
Format	Compatible with SMPTE 292M (1080i 50, 1080i 59.94, 1080i 60)
Input type	75 Ω BNC, internally terminated
Cable loss accommodation	0–20 dB attenuation with 1/SQRT(f) characteristic at 1/2 of serial rate.
Launch amplitude accommodation, typical	800 mV ± 10% for full specification

Table 39: HD SDI Input (cont.)

Characteristic	Description
Jitter tolerance, typical	0.35 ± 0.1 UI p-p above 1 MHz. Increases proportional to 1/f ≤ 1 MHz to a maximum of 10 UI at low frequencies.
Return loss, typical	≥ 20 dB, 5 MHz to 2.0 GHz

Table 40: Video signal content

Characteristic	Description
Accuracy of synthesizer generated test signals, typical	0.2%
Signal rise and fall time, typical	Y =16.6 ns , Cb/Cr =33.3 ns except for RP219 which has Y = 27.5 ns Y and Cb/Cr = 55 ns

Table 41: Synthesizer generated 3 Gb/s test signals

Characteristic	Description
Color Bars	100% Color Bars, 75% Color Bars, Matrix Color Bar (SMPTE RP219) Color Bars
Linearity	5 Step Staircase, Ramp, Valid Ramp
Flat Field	0% Flat Field, 10% Flat Field, 20% Flat Field, 30% Flat Field, 40% Flat Field, 50% Flat Field, 60% Flat Field, 70% Flat Field, 80% Flat Field, 90% Flat Field, 100% Flat Field
Monitor	100% Red Field, 75% Red Field, 100% Blue Field, 75% Blue Field, 100% Green Field, 75% Green Field, Convergence
Pulse bar	2T60 Pulse and Bar
SDI	Equalizer Test, PLL Test, SDI Matrix Because of the interleaving method on Level B, the appearance of the pathological signals will be different in order to get the correct patterns on the serial link. The pathological patterns will also persist for two active line times instead of one.

Table 42: Embedded audio and ancillary data

Characteristic	Description
Generator ancillary data	SMPTE 352 Embedded Ancillary Data is placed on the video outputs as per SMPTE 425M
Audio data (converter mode)	On Level A, embedded audio from a given input line is passed to the first line derived from that input. For Level B, the audio is placed on both lines derived from the input. This effectively doubles the number of audio channels that are active in a level B signal.
Audio control packets (converter mode)	Embedded audio control packets are passed to the output, but when necessary they are delayed a frame to allow them to be placed on line 9 as specified in SMPTE 299M.
VPID (converter mode)	SMPTE 352 embedded ancillary data on the input is stripped and new SMPTE 352 data that is correct for the output format is placed on the video outputs as per SMPTE 425M. SMPTE 352 packets are normally placed immediately after EAV as the first ANC on line 10. If time code is present, the VPID will be shifted to happen after the ANC timecode.

Table 42: Embedded audio and ancillary data (cont.)

Characteristic	Description
ANC timecode (converter mode)	Embedded ANC timecode is passed on to the output Embedded timecode is normally on line 10, but on Level A outputs, line 10 of the input maps to line 19 and 20 on the output. So, in order to prevent delaying the timecode a frame, it is output on line 19. Level B outputs do not have this issue, so timecode passes through on line 10 and is placed on virtual link A only.
Other ANC data (converter mode)	Embedded ANC such as Closed Caption is passed on to the output For Level A, embedded data passes on immediately but ends up on a higher line number due to the conversion mapping. On Level B, the data ends up on the same line number as it was on the input, and is placed on virtual link A only.

Table 43: Supported input and output formats (SMPTE 274M to SMPTE 425M standards; Level A mapping structure 1 and Level B fast progressive)

Allowed converter input formats	Desired output format	Conversion process
	Output may be level A or B 4:2:2 YCbCr 10 bits at fast progressive rates:	Lines repeated to convert from interlaced to progressive signal
50i →	50p	
59.94i →	59.94p	
60i →	60p	

Mechanical Characteristics The following table lists the mechanical characteristics of the HD3G7 module.

Table 44: Mechanical characteristics

Characteristic	Description	
Dimensions	Height	41.5 mm (1.63 in)
	Width	78.4 mm (3.1 in)
	Depth	394 mm (15.5 in)
Weight	340 g (0.75 lb)	
Shipping weight	760 g (1.7 lb)	

Environmental Characteristics

The following table lists the environmental characteristics of the HD3G7 module.

Table 45: Environmental characteristics

Characteristic		Description
Temperature	Operating	0 °C to +50 °C, with 15° C/hour maximum gradient, non-condensing, derated 1° C per 300 m above 1,500 m altitude
	Non-operating	-20 °C to +60 °C, with 15° C/hour maximum gradient
Relative Humidity	Operating	20% to 80% RH (relative humidity) at up to +30° C; Maximum Wet-Bulb Temperature of +29° C (relative humidity decreases to 20% RH at +50° C)
	Non-operating	5% to 90% RH (Relative Humidity) at up to +40° C; Maximum Wet-Bulb Temperature of +40° C (relative humidity decreases to 55% RH at +50° C)
Altitude	Operating	To 4.5 km (15,000 feet) Maximum operating temperature decreases 1 °C each 300 m above 1.5 km.
	Non-operating	To 15 km (50,000 feet)
Vibration	Operating	0.27 G _{rms} , 5 Hz to 500 Hz, 10 minutes per axis, three axes
	Non-operating	2.28 G _{rms} , 5 Hz to 500 Hz, 10 minutes per axis, three axes

HDLG7 Specifications

The following tables list the electrical, mechanical, and environmental characteristics of the HDLG7 HD Dual Link Video Generator.

Electrical Characteristics

The following tables in this section list the electrical characteristics of the HDLG7 module.

Table 46: 4:2:2 serial digital video signal input

Characteristic	Description
Number of inputs	1
Format	Compatible with SMPTE 292M. (See Table 56.)
Input type	75 Ω BNC
Cable loss accommodation	0-20 dB attenuation with 1/SQRT(f) characteristic at 1/2 of serial rate.
Launch amplitude accommodation, typical	800 mV ± 10% for full specification 800 mV (plus-min) ³ 30% up to 20 dB cable attenuation
Jitter tolerance, typical	0.35 ± 0.1 UI p-p above 1 MHz. Increases proportional to 1/f below 1 MHz.
Return loss	≥ 15 dB, 5 MHz to 750 MHz ≥
	10 dB, 750 MHz to 1.485 GHz

Table 47: Dual link serial video outputs

Characteristic	Description
Number of outputs	2 on each channel (link)
Format	Compatible with SMPTE 372M and SMPTE 292M
Output type	75 Ω BNC
Output level	800 mV \pm 10%
Rise and fall times	270 ps max. (20% to 80%)
Jitter, typical	135 ps max. (0.2 UI alignment jitter)
Return loss	\geq 15 dB, 5 MHz to 750 MHz \geq 10 dB, 750 MHz to 1.485 GHz

Table 48: Video signal content

Characteristic	Description
Conversion accuracy, typical	0.4%
Accuracy of synthesizer generated test signals, typical	0.2%
Timing offset of Link B in reference to Link A	\pm 200 ns min. Adjustment in steps of the clock period (13.5 ns)

Table 49: Synthesizer generated HD test signals

Characteristic	Description
Color Bars	100% Color Bars, 75% Color Bars, SMPTE RP219 Color Bars ^{1, 2}
Linearity	5 Step Staircase, Ramp, Valid Ramp ²
Flat Field	0% Flat Field, 10% Flat Field, 20% Flat Field, 30% Flat Field, 40% Flat Field, 50% Flat Field, 60% Flat Field, 70% Flat Field, 80% Flat Field, 90% Flat Field, 100% Flat Field
Monitor	100% Red Field, 75% Red Field, 100% Blue Field, 75% Blue Field, 100% Green Field, 75% Green Field, Convergence
Pulse bar	2T30 Pulse and Bar
SDI	Equalizer Test, PLL Test, SDI Matrix

¹ SMPTE RP219 Color Bars refer to SMPTE RP219 Color Bar (I/Q Even).

² Not available in 2K-format mode of operation.

Table 50: Synthesizer generated projector test patterns

Characteristic		Description			
Color Bars	Color Bar Patch-1	The color bar levels are as follows:			
		Levels	X	Y	Z
		White	3794	3960	3890
		Yellow	3494	3853	1221
		Cyan	2911	3618	3890
		Green	2417	3493	1222
		Magenta	3289	2421	3814
		Red	2901	2171	100
		Blue	2014	1416	3816
	Black	16	16	16	
	Color Bar Patch-2	The color bar levels are as follows:			
		Levels	X	Y	Z
		White	3794	3960	3890
		Yellow	3461	3777	2065
		Cyan	3085	3590	3756
		Green	2767	3493	2325
		Magenta	3062	2421	3497
Red		2738	2171	1233	
Blue		1800	1416	3203	
Black	16	16	16		

Table 50: Synthesizer generated projector test patterns (cont.)

Characteristic	Description			
Linearity	Step Black to White			
	Window 10 step staircase signal, which is positioned in the center of the frame or field. It is 20% of the vertical width and 80% of the horizontal width. Each step is at the following levels:			
	Levels	X	Y	Z
	Background	1565	1633	1604
	Step1	379	396	389
	Step2	759	792	778
	Step3	1138	1188	1167
	Step4	1518	1584	1556
	Step5	1897	1980	1945
	Step6	2276	2376	2334
	Step7	2656	2772	2723
	Step8	3035	3168	3112
	Step9	3415	3564	3501
Step10	3794	3960	3890	
Step Black to Dark Gray	Step Black to Dark Gray			
	Window 10 step staircase signal, which is positioned in the center of the frame or field. It is 20% of the vertical width and 80% of the horizontal width. Each step is at the following levels:			
	Levels	X	Y	Z
	Background	122	128	125
	Step1	122	128	125
	Step2	245	255	251
	Step3	367	383	376
	Step4	490	511	502
	Step5	612	639	627
	Step6	734	766	753
	Step7	857	894	878
	Step8	979	1022	1004
	Step9	1101	1150	1129
Step10	1224	1277	1255	
Horizontal Gradient	Ramp signal in the horizontal plane with the Y component advancing one level step for each horizontal pixel across the active line. By using the up/down arrow keys, the Y value from 16 to 3960 can be observed. The X component value is 0.95808 of the Y component except a minimum of 16. The Z component value is 0.98232 of the Y component except a minimum of 16.			
Vertical Gradient	Ramp signal in the vertical plane with the Y component advancing one level step for each vertical pixel (each active line). By using the up/down arrow keys, the Y value from 16 to 3960 can be observed. The X component value is 0.95808 of the Y component except a minimum of 16. The Z component value is 0.98232 of the Y component except a minimum of 16.			

Table 50: Synthesizer generated projector test patterns (cont.)

Characteristic	Description
Flat Field	Black Flat Field, White Flat Field, Black to White Step-1, Black to White Step-2, Black to White Step-3, Black to White Step-4, Black to White Step-5, Black to White Step-6, Black to White Step-7, Black to White Step-8, Black to White Step-9, Black to White Step-10, Black to Gray Step-1, Black to Gray Step-2, Black to Gray Step-3, Black to Gray Step-4, Black to Gray Step-5, Black to Gray Step-6, Black to Gray Step-7, Black to Gray Step-8, Black to Gray Step-9, Black to Gray Step-10 (levels are the same as the levels listed in the Linearity specification, previously in this table)
Monitor	Red-1 Field, Red-2 Field, Green-1 Field, Green-2 Field, Blue-1 Field, Blue-2 Field, Cyan-1 Field, Cyan-2 Field, Magenta-1 Field, Magenta-2 Field, Yellow-1 Field, Yellow-2 Field, Grid, Checkerboard, Aspect Ratio (color field levels are the same as the levels listed in the Color Bars specification, previously in this table)
Pulse Bar	Window
SDI	Equalizer Test, PLL Test, SDI Matrix

Table 51: Embedded audio and ancillary data

Characteristic	Description
Embedded audio	Embedded audio on 4:2:2 video input is placed on the Link A video outputs as per SMPTE 372M. Embedded audio and ancillary data is selectable from the front panel to be inserted on Link A per SMPTE 372M standard or on Link B or on both for testing purposes.
Ancillary data	Embedded ancillary data on 4:2:2 video input is placed on the Link A video outputs as per SMPTE 372M.

Table 52: Supported input and output formats (SMPTE 274M to SMPTE 372M standards)

Desired output format	Allowed converter input formats	Conversion process
4:2:2 YCbCr 10 bits at fast progressive rates	50i ! 50P 59.94i ! 59.94p 60i ! 60p Progressive input formats not supported.	<ul style="list-style-type: none"> ■ Lines repeated to convert from interlaced to progressive signal.
4:4:4 YCbCr 10 bits or 4:4:4:4 YCbCrA 10 bits	All ¹ (Output format rate and scanning unchanged from input.)	<ul style="list-style-type: none"> ■ Additional Cb and Cr samples are upinterpolated. ■ Alpha channel content optionally added.
4:4:4 YCbCr 12 bits	All ¹ (Output format rate and scanning unchanged from input.)	<ul style="list-style-type: none"> ■ Additional Cb and Cr samples are upinterpolated. ■ Y least significant 2 bits set to zero.
4:4:4 RGB 10 bits or 4:4:4:4 RGBA 10 bits	All ¹ (Output format rate and scanning unchanged from input.)	<ul style="list-style-type: none"> ■ Additional Cb and Cr samples are upinterpolated. ■ Linear conversion from YCbCr to RGB. ■ Alpha channel content optionally added.

Table 52: Supported input and output formats (SMPTE 274M to SMPTE 372M standards) (cont.)

Desired output format	Allowed converter input formats	Conversion process
4:4:4 RGB 12 bits	All ¹ (Output format rate and scanning unchanged from input.)	<ul style="list-style-type: none"> ■ Additional Cb and Cr samples are upinterpolated. ■ Linear conversion from YCbCr to RGB.
4:2:2 YCbCr 12 bits or 4:2:2:4 YCbCr 12 bits	All ¹ (Output format rate and scanning unchanged from input.)	<ul style="list-style-type: none"> ■ Least significant 2 bits set to zero. ■ Alpha channel content optionally added.
2K 4:4:4 RGB 12 bits or 2K 4:4:4 XYZ 12 bits	All ¹ progressive or segmented up to 30 Hz. Interlaced input at 50, 59.94, or 60 Hz will be considered as 25, 60/1.001, or 60 segmented.	<ul style="list-style-type: none"> ■ Additional Cb and Cr samples are upinterpolated. ■ Linear conversion from YCbCr to RGB or XYZ as desired. ■ Flat field “pillar boxes” (64 samples wide) added to left and right of active video.

¹ All indicates 1920 x 1080 30, 30/1.001, 25, 24, and 24/1.001 progressive, PsF or 60, 60/1.001, and 50 interlaced. Note that 30, 30/1.001, and 25 PsF inputs will be decoded as 60, 60/1.001, and 50 interlace.

Mechanical Characteristics The following table lists the mechanical characteristics of the HDLG7 module.

Table 53: Mechanical characteristics

Characteristic	Description	
Dimensions	Height	41.5 mm (1.63 in)
	Width	78.4 mm (3.1 in)
	Depth	394 mm (15.5 in)
Weight	340 g (0.75 lb)	

Environmental Characteristics The following table lists the environmental characteristics of the HDLG7 module.

Table 54: Environmental characteristics

Characteristic	Description	
Temperature	Operating	0 °C to +50 °C
	Non-operating	-20 °C to +60 °C
Relative Humidity	Operating	20% to 80% (No condensation); Maximum wet-bulb temperature 29.4 °C
	Non-operating	5% to 90% (No condensation); Maximum wet-bulb temperature 40.0 °C

Table 54: Environmental characteristics (cont.)

Characteristic	Description	
Altitude	Operating	To 4.5 km (15,000 feet) Maximum operating temperature decreases 1 °C each 300 m above 1.5 km.
	Non-operating	To 15 km (50,000 feet)
Vibration	Operating	3.04 m/s ² (0.31 G _{rms}), 5 Hz to 500 Hz, 10 min, three axes
	Non-operating	23.3 m/s ² (2.38 G _{rms}), 5 Hz to 500 Hz, 10 min, three axes
Shock, Non-operating	294 m/s ² (30 G), half-sine, 11 ms duration	

HDVG7 Specifications

The following tables list the electrical and environmental characteristics of the HDVG7 Generator module.

Electrical Characteristics The following tables in this section list the electrical characteristics of the HDVG7 module.

Table 55: Serial digital video signal outputs

Characteristic	Performance requirements	Reference information
Connector	BNC	
Number of outputs	2	SIGNAL 1 and SIGNAL 2
Bit Rate	1.485 Gbps	
	1.485/1.001 Gbps	
Signal amplitude, typical	800 mV	
Rise and fall times, typical	≤ 270 ps	20% to 80%
Jitter, typical	≤ 135 ps	Alignment jitter
Return loss	≥ 15 dB	5 MHz to 750 MHz
	≥ 10 dB	750 MHz to 1.485 GHz

Table 56: Serial digital black signal outputs (Option BK only)

Characteristic	Performance requirements	Reference information
Connector	BNC	
Number of outputs	2	BLACK 1 and BLACK 2
Bit Rate	1.485 Gbps	
	1.485/1.001 Gbps	
Signal amplitude, typical	800 mV	

Table 56: Serial digital black signal outputs (Option BK only) (cont.)

Characteristic	Performance requirements	Reference information
Rise and fall times, typical	≤ 270 ps	20% to 80%
Jitter, typical	≤ 135 ps	Alignment jitter
Return loss	≥ 15 dB	5 MHz to 750 MHz
	≥ 10 dB	750 MHz to 1.485 GHz

Table 57: Embedded audio

Characteristic	Performance requirements	Reference information
Number of channels	16 channels in 4 groups; 8 AES/EBU audio pairs	
Audio tones	Frequency	Silence to 20 kHz; 31 discrete settings
	Level	–60 to 0 dBFS in 1 dB steps
	Pre-emphasis	Emphasis status bits can be inserted.

Environmental Characteristics

The following table lists the environmental characteristics of the HDVG7 module.

Table 58: Environmental characteristics

Characteristic	Description
Temperature	Operating 0 °C to +50 °C
	Non-operating –20 °C to +60 °C
Relative Humidity	Operating 20% to 80% (No condensation); Maximum wet-bulb temperature 29.4 °C
	Non-operating 5% to 90% (No condensation); Maximum wet-bulb temperature 40.0 °C
Altitude	Operating To 4.5 km (15,000 feet) Maximum operating temperature decreases 1 °C each 300 m above 1.5 km.
	Non-operating To 15 km (50,000 feet)
Vibration	Operating 3.04 m/s ² (0.31 G _{rms}), 5 Hz to 500 Hz, 10 min, three axes
	Non-operating 23.3 m/s ² (2.38 G _{rms}), 5 Hz to 500 Hz, 10 min, three axes
Shock, non-operating	294 m/s ² (30 G), half-sine, 11 ms duration

Performance Verification

This section provides procedures to verify the performance and functionality of the TG700 mainframe and related modules.

Performance Verification Preparation

Do the following before starting any of the following performance verification procedures:

Power On Default Settings

Before you begin a performance verification procedure, you can save your required instrument settings in the Power On Default preset.

If the instrument settings are saved in the Power On Default preset, you can recall the settings after the performance verification procedure is completed by turning off and on the power.

Module Initialization

Perform the following procedure before doing any performance verification procedures. This will check that the module turns on correctly.

1. Connect the power cord.
2. Check for error messages as the instrument starts and record the results in the appropriate test record.
3. Run diagnostics:
 - a. Use the up (▲) arrow button to select **UTILITY**.
 - b. Press the **ENTER** button.
 - c. Use the up (▲) arrow button to select **Diagnostics**.
 - d. Press the **ENTER** button and follow the instructions on the display.
 - e. After the diagnostics testing is complete, press the **CANCEL** button twice to exit the Diagnostics menu.
 - f. Record the results in the appropriate test record.
4. Load the factory preset:
 - a. Use the up down (▼) arrow button to select **Preset**.
 - b. Press the **ENTER** button to select **RECALL**.
 - c. Press the left (◀) arrow button until **Factory Default** appears.
 - d. Press the **ENTER** button to load the preset.
5. When loading is complete, press the **CANCEL** button to exit the Factory Default menu.

Warm Up The TG700 and test equipment must have had a warm-up period of at least 20 minutes before you start a performance verification procedure.

TG700 Mainframe Performance Verification

The following procedures verify the functionality of the TG700 TV Signal Generator Platform mainframe.

Required Equipment The TG700 and test equipment must have had a warm-up period of at least 20 minutes. The following table lists the required equipment for this procedure.

Table 59: Required Equipment for TG700 mainframe performance verification

Item	No.	Minimum requirement	Recommended equipment
Analog genlock module	1		Tektronix AGL7
Frequency counter	1	Frequency range: 0.1 Hz to 1250 MHz Precision: 8 digits or higher	ANRITSU MF 1603A
75 Ω BNC cable	1	Length: 42 inches	Tektronix part number 012-0074-00
75 Ω feed-through terminator	1		Tektronix part number 011-0103-02

Test Record Photocopy this table and use it to record the performance test results.

Table 60: TG700 mainframe test record

Serial Number	Cal Date	Temperature	Humidity	
Step	Function Tested	Minimum	Cal Data	Maximum
1.	Subcarrier Frequency	3.5795418 MHz		3.5795490 MHz

Procedures Be sure you have performed the performance verification preparation before proceeding. (See page 35, *Performance Verification*.)



WARNING. *Dangerous electric shock hazards exist inside the TG700 mainframe. Only qualified service personnel should perform these procedures.*

Subcarrier Frequency.

This test verifies the subcarrier frequency accuracy of black burst signals. The following equipment is required for the test:

- Frequency counter
- 75 Ω BNC cable
- 75 Ω feed-through terminator

Perform the following procedure to verify the subcarrier frequency accuracy of black burst signals.

1. Use the 75 Ω BNC cable and the 75 Ω feed-through terminator to connect the BLACK 1 connector on the AGL7 Generator module to the INPUT A connector on the frequency counter as shown in the following figure.

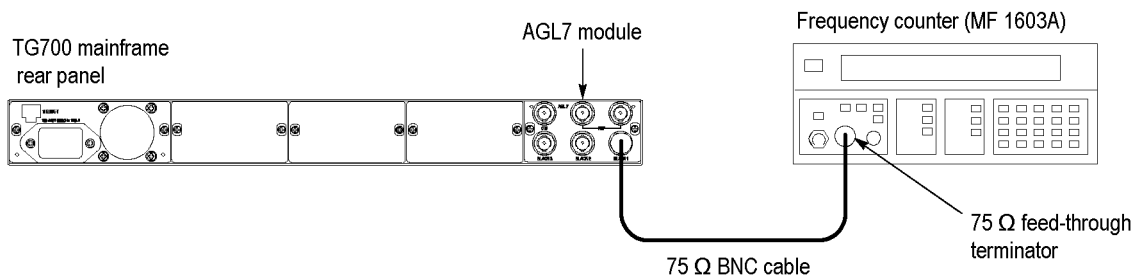

Figure 2: Equipment connection for verifying subcarrier frequency

2. Set the frequency counter to the frequency measurement mode (if necessary), and then set the Gate Time to $< 2s$.
3. Output the NTSC subcarrier calibration signal as follows:
 - a. Press **MODULE**, **FORMAT**, and **FRONT PANEL ENABLE** simultaneously, and then release the **MODULE** and **FORMAT** buttons to restart the instrument in Factory mode.
 - b. Press **MODULE** to display the AGL7 main menu.
 - c. Press the up (**▲**) or down (**▼**) arrow button to select **SELECT OUTPUT**.
 - d. Press the left (**◀**) or right (**▶**) arrow button to select **BLACK 1**, and then press **ENTER** to access the OUTPUT submenu.
 - e. Press the left (**◀**) or right (**▶**) arrow button to select **CAL**, and then press **ENTER** to access the SIGNAL submenu.
 - f. Press the left (**◀**) or right (**▶**) arrow button to select **NTSC Subcarrier (1Vp-p)**, and then press **ENTER**.
4. Set the frequency counter to trigger on the input, and then verify that the displayed frequency is within the range of 3.5795418 MHz to 3.5795490 MHz.

This completes the TG700 mainframe performance verification procedure. If you require further assistance, contact your nearest Tektronix Service Center.

AG7 Module Performance Verification

The following procedures verify the functionality of the AG7 Audio Generator module.

Required Equipment The following table lists the required equipment for the following procedure.

Table 61: Required equipment for AG7 performance verification

Item	No.	Minimum requirements	Recommended equipment
Digital Audio Monitor	1		Tektronix 764
Oscilloscope	1	Bandwidth: 200 MHz or higher	Tektronix TDS540D
75 Ω BNC cable	1	Length: 42 inches	Tektronix part number 012-0074-00
75 Ω feed-through terminator	1		Tektronix part number 011-0103-02
75 Ω coaxial terminator	1		Tektronix part number 011-0102-01

Test Record Photocopy this table and use it to record the performance test results.

Table 62: AG7 test record

Serial Number	Cal Date		Temperature	Humidity	
Step	Function Tested		Minimum	Cal Data	Maximum
1.	AES/EBU Serial Digital Audio Output Level	1+2	900 mV	mV	1100 mV
		3+4	900 mV	mV	1100 mV
		5+6	900 mV	mV	1100 mV
		7+8	900 mV	mV	1100 mV
2.	SILENCE Output Level		900 mV	mV	1100 mV
3.	48 kHz Clock Output Level (CMOS compatible)	High	2.1V	OK	
		Low		OK	0.8V

Procedures Be sure you have performed the performance verification preparation before proceeding. (See page 35, *Performance Verification*.)

Performance verification procedures can be performed individually if desired.



WARNING. *Dangerous electric shock hazards exist inside the TG700 mainframe. Only qualified service personnel should perform these procedures.*

Serial Digital Audio Outputs.

This test verifies that serial digital audio signals are output correctly from the 1+2, 3+4, 5+6, 7+8, and SILENCE connectors. The following equipment is required for this test:

- Oscilloscope
- Digital audio monitor
- 75 Ω BNC cable
- 75 Ω feed-through terminator
- 75 Ω coaxial terminator

Perform the following procedure to verify that serial digital audio signals are output correctly from the 1+2, 3+4, 5+6, 7+8, and SILENCE connectors.

1. Use the 75 Ω BNC cable and the 75 Ω feed-through terminator to connect the 1+2 connector on the AG7 Generator module to the oscilloscope CH1 input as shown in the following figure.

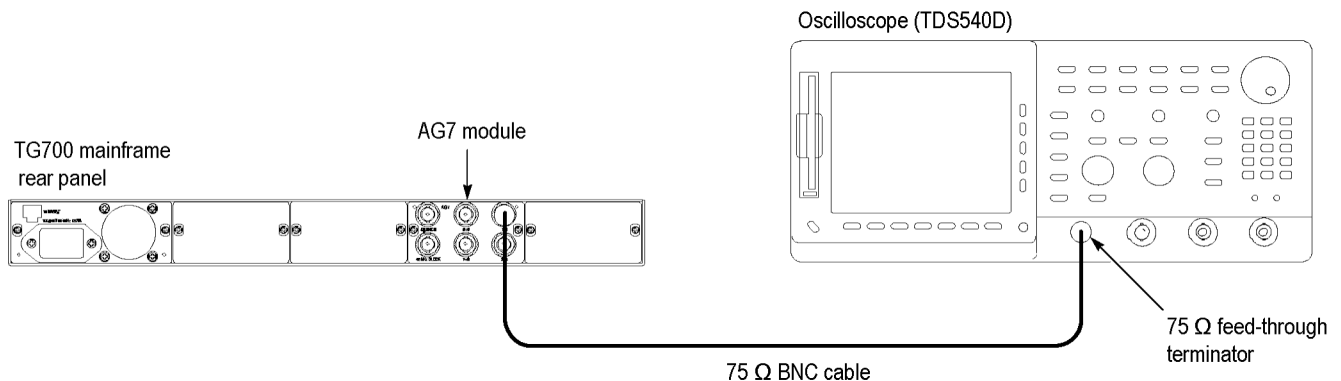

Figure 3: Initial equipment connection for verifying the serial digital audio outputs

2. Set the oscilloscope settings as follows:

Control	Setting
Vertical	200 mV/div
Horizontal	100 ns/div
Acquire	Sample
Trigger position	50%
Trigger slope	Rising Edge
Input impedance	1 M Ω
Measure	Amplitude

3. Recall the Factory Default preset as follows:

- a. Press the **MODULE** button to display the TG700 main menu.
 - b. Use the up (**▲**) or down (**▼**) arrow button to select **RECALL**.
 - c. Use the left (**◀**) or right (**▶**) arrow button to select **Factory Default**.
 - d. Press **ENTER** to recall the factory default settings.
4. Use the oscilloscope to measure that the signal amplitude is within the range of 900 mV to 1100 mV.
5. Change the BNC cable connection from the 1+2 connector to the 3+4 connector on the AG7 Generator module and repeat step 4.
6. Change the BNC cable connection from the 3+4 connector to the 5+6 connector on the AG7 Generator module and repeat step 4.
7. Change the BNC cable connection from the 5+6 connector to the 7+8 connector on the AG7 Generator module and repeat step 4.
8. Change the BNC cable connection from the 7+8 connector to the SILENCE connector on the AG7 Generator module and repeat step 4.
9. Change the BNC cable connection from the SILENCE connector to the 1+2 connector on the AG7 Generator module.
10. Disconnect the BNC cable and the 75 Ω terminator from the oscilloscope CH1 input connector, and then connect the BNC cable to the CH1-2 BNC connector on the digital audio monitor rear panel as shown in the following figure.
11. Use the 75 Ω coaxial terminator to terminate the other loop through to the CH1-2 BNC connector on the digital audio monitor rear panel.

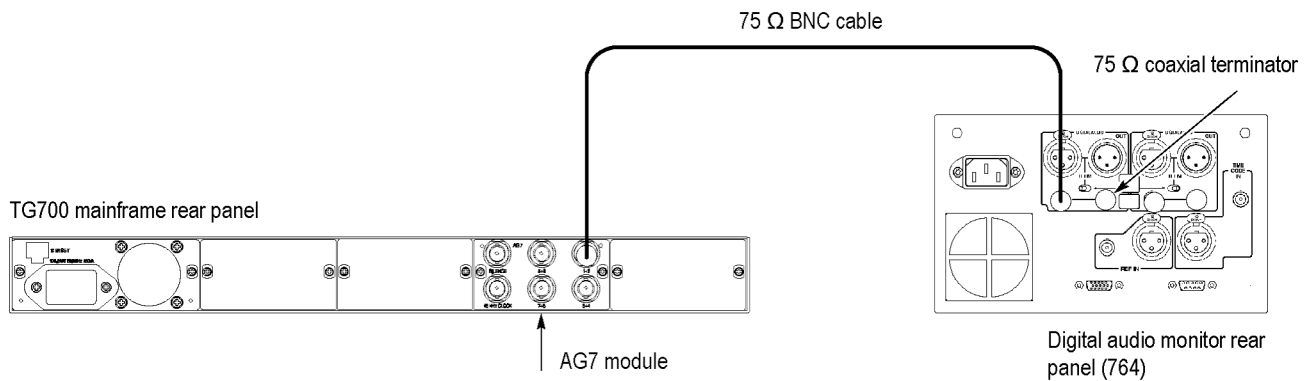

Figure 4: Second equipment connection for verifying the serial digital audio outputs

12. On the digital audio monitor front panel, press **MENU** to display the menu.
13. Select the **Input** item from the menu, and select **CH1-2 input: BNC-unbalanced** item from the submenu.
14. On the digital audio monitor front panel, press **CLEAR** to clear the menu.
15. On the digital audio monitor front panel, press **CH STATUS** to display **CHANNEL STATUS** view.
16. In the view, check that CRC errors are not displayed.
17. On the digital audio monitor front panel, press **Audio View**.
18. Verify that the digital audio monitor bar graphs show both Channel 1 and Channel 2 at -20 dBfs.
19. Change the BNC cable connection from the 1+2 connector to the 3+4 connector on the AG7 Generator module and repeat step 12 to step 18.
20. Change the BNC cable connection from 3+4 connector to 5+6 connector on the AG7 Generator module and repeat step 12 to step 18.
21. Change the BNC cable connection from 5+6 connector to 7+8 connector on the AG7 Generator module and repeat step 12 to step 18.
22. Change the BNC cable connection from 7+8 connector to SILENCE connector on the AG7 Generator module and repeat step 12 to step 18.

48 kHz Clock Output.

This test verifies that 48 kHz clock signal are output correctly from the 48 kHz CLOCK connector. The following equipment is required for this test:

- Oscilloscope
- 75 Ω BNC cable
- 75 Ω feed-through terminator

Perform the following procedure to verify that 48 kHz clock signal is output correctly from the 48 kHz CLOCK connector.

1. Use the 75 Ω BNC cable and the 75 Ω feed-through terminator to connect the 48 kHz CLOCK connector on the AG7 Generator module to the oscilloscope CH1 input as shown in the following figure.

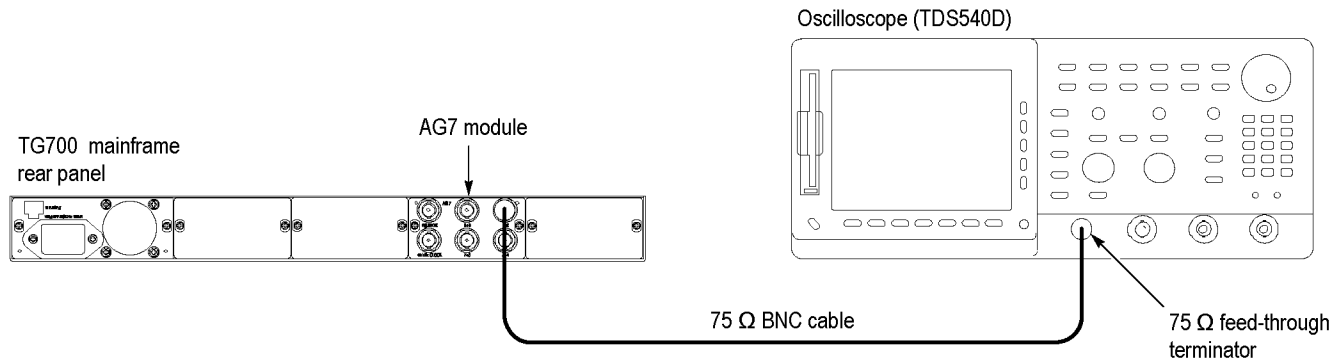

Figure 5: Equipment connection for verifying the 48 kHz clock output

2. Set the oscilloscope settings as follows:

Control	Setting
Vertical	500 mV/div
Horizontal	10 μs/div
Record Length	1000
Acquire menu	Sample
Trigger position	50%
Trigger slope	Rising Edge
Input impedance	1 MΩ
Measure	Amplitude

3. Use the oscilloscope to measure that the signal amplitude is as follows:

Low: < 0.8 V

High: > 2.1 V

This completes the AG7 module performance verification procedure. If you require further assistance, contact your nearest Tektronix Service Center.

AGL7 Module Performance Verification

The following procedures verify the functionality of the AGL7 Analog Genlock module.

Required Equipment The following table lists the required equipment for the following procedure.

Table 63: Required equipment for AGL7 performance verification

Item	No.	Minimum requirement	Recommended equipment
Oscilloscope	1	Bandwidth: 200 MHz or higher	Tektronix TDS540D
Video measurement set	1		Tektronix VM700T Option 01/11
Waveform vector monitor	1		Tektronix 1765
TV signal generator	1		Tektronix TG700 with AGL7 Analog Genlock module
Frequency counter	1	Frequency range: 0.1 Hz to 1250 MHz Precision: 7 digits or higher	ANRITSU MF 1603A
75 Ω BNC cable	4	Length: 42 inches	Tektronix part number 012-0074-00
75 Ω feed-through terminator	1		Tektronix part number 011-0103-02
75 Ω coaxial terminator	2		Tektronix part number 011-0102-01

Test Record Photocopy this table and use it to record the performance test results.

Table 64: AGL7 test record

Serial Number	Cal Date		Temperature	Humidity	
Step	Function Tested		Minimum	Cal Data	Maximum
Black Output (NTSC)					
1.	Blanking Level	BLACK 1	-50 mV	mV	+50 mV
		BLACK 2	-50 mV	mV	+50 mV
		BLACK 3	-50 mV	mV	+50 mV
2.	Burst Amplitude	BLACK 1 (Peak to Peak Value)	280.0 mV	mV	291.4 mV
		BLACK 2 (Peak to Peak Value)	280.0 mV	mV	291.4 mV
		BLACK 3 (Peak to Peak Value)	280.0 mV	mV	291.4 mV
3.	Sync Amplitude	BLACK 1	280.0 mV	mV	291.4 mV
		BLACK 2	280.0 mV	mV	291.4 mV
		BLACK 3	280.0 mV	mV	291.4 mV
4.	Subcarrier Frequency		3.5795444 MHz		3.5795464 MHz
Tri-Level Sync Output					
4.	Blanking Level	BLACK 2	-50 mV	mV	+50 mV
		BLACK 3	-50 mV	mV	+50 mV

Table 64: AGL7 test record (cont.)

Serial Number	Cal Date		Temperature	Humidity	
Step	Function Tested		Minimum	Cal Data	Maximum
5.	Sync Amplitude plus	BLACK 2	294.0 mV	mV	306.0 mV
		BLACK 3	294.0 mV	mV	306.0 mV
6.	Sync Amplitude minus	BLACK 2	294.0 mV	mV	306.0 mV
		BLACK 3	294.0 mV	mV	306.0 mV

Procedures The following procedure determines if the AGL7 Analog Genlock module is operating correctly.

Be sure you have performed the performance verification preparation before proceeding. (See page 35, *Performance Verification*.)



WARNING. *Dangerous electric shock hazards exist inside the TG700 mainframe. Only qualified service personnel should perform these procedures.*

Genlock Function.

This test verifies that the genlock function is operating correctly. The following equipment is required for the test:

- TV signal generator (TG700 mainframe with AGL7 module)
- Waveform vector monitor
- Four 75 Ω BNC cables
- Three 75 Ω coaxial terminators

Perform the following procedure to verify that the genlock function is functioning correctly.

1. Use a 75 Ω BNC cable to connect the CW connector on the AGL7 Genlock module to the BLACK 2 connector on the TV signal generator (AGL7 module) as shown in the following figure.
2. Use a 75 Ω BNC cable to connect the REF connector on the AGL7 Genlock module to the BLACK 1 connector on the TV signal generator (AGL7 module) as shown in the following figure.
3. Use a 75 Ω BNC cable to connect the other REF connector on the AGL7 Genlock module to the A connector on the waveform vector monitor as shown in the following figure. (See Figure 6.)
4. Use a 75 Ω BNC cable to connect the BLACK 1 connector on the AGL7 Genlock module to the B connector on the waveform vector monitor rear panel as shown in the following figure. (See Figure 6.)
5. Use the 75 Ω coaxial terminators to terminate the A and B loop through connectors on the waveform vector monitor rear panel.

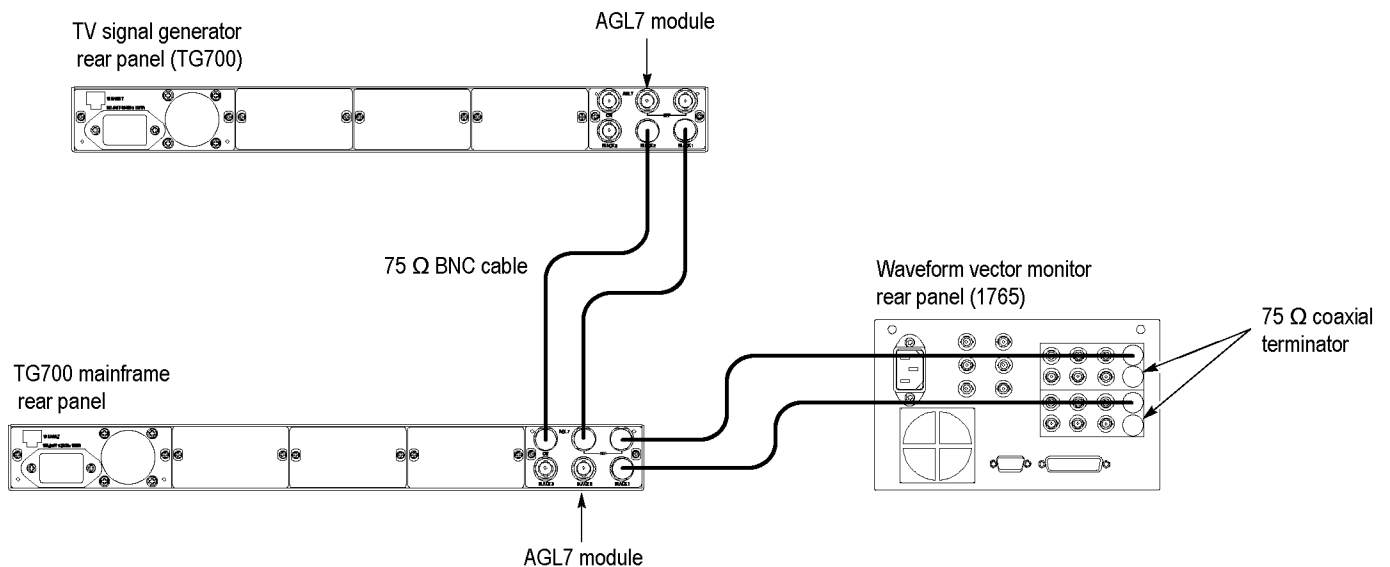

Figure 6: Equipment connections for verifying the genlock function

6. Set the TV signal generator (AGL7 module) settings as follows:

Control	Setting
Signal format	PAL
Test signal	Black Burst

7. Set the waveform vector monitor settings as follows:

Control	Setting
CONFIG	REFERENCE NTSC EXTREF: A PAL EXTREF :B
DISPLAY	VECTOR
INPUT	CH-A and CH-B
OVERLAY	ON
EXT REF	OFF

8. Press the **GAIN** menu button on the waveform vector monitor front panel to display the Gain menu.
9. In the Gain menu, select X5 and VARIABLE.
10. Align the PAL burst vector with the compass rose of the display.
11. Recall the Factory Default preset as follows:
- Press the **MODULE** button to display the TG700 main menu.
 - Press the up (▲) or down (▼) arrow button to select **RECALL**.
 - Press the left (◀) or right (▶) arrow button to select **Factory Default**.
 - Press **ENTER** to recall the factory default settings.
12. Set the genlock source and output signal of the AGL7 Genlock module as follows:
- Press the **MODULE** button to display the AGL7 main menu.
 - Press the up (▲) or down (▼) arrow button to select **GENLOCK**, and then press **ENTER** to access the GENLOCK submenu.
 - Press the left (◀) or right (▶) arrow button to select **PAL Burst**, and then press **ENTER**.
 - Press the **CANCEL** button to return the module main menu.
 - Press the up (▲) or down (▼) arrow button to select **SELECT OUTPUT**.
 - Press the left (◀) or right (▶) arrow button to select **BLACK 1**, and then press **ENTER** to access the OUTPUT submenu.

- a. Press and hold the **MODULE**, **FORMAT**, and **FRONT PANEL ENABLE** buttons on the TV signal generator (TG700) simultaneously until **TG700 Preset** appears in the display, then release the **MODULE** and **FORMAT** buttons to restart the instrument in Factory mode.
 - b. Press the up (**▲**) or down (**▼**) arrow button to select **SELECT OUTPUT**.
 - c. Press the left (**◀**) or right (**▶**) arrow button to select **BLACK 1**, and then press **ENTER** to access the OUTPUT submenu.
 - d. Press the left (**◀**) or right (**▶**) arrow button to select **CAL**, and then press **ENTER** to access the SIGNAL submenu.
 - e. Press the left (**◀**) or right (**▶**) arrow button to select **NTSC Subcarrier (1Vp-p)**, and then press **ENTER**.
26. Press the left (**◀**) or right (**▶**) arrow button to select **CW**, and then press **ENTER**.
 27. Verify that the displayed vector display is locked and the **EXT.REF** LED on the TG700 mainframe front panel lights.
 28. Change the BNC cable connection from **BLACK 2** connector to **BLACK 3** connector on the TV signal generator (AGL7 module).
 29. Set the TV signal generator (AGL7 module) so that 1080 59.94i trilevel sync signal is output from the **BLACK 3** connector.
 30. Press the left (**◀**) or right (**▶**) arrow button to select **HD SYNC**, and then press **ENTER**.
 31. Verify that the displayed vector display is locked and the **EXT.REF** LED on the TG700 mainframe front panel lights.

Trilevel Sync Outputs.

This test verifies the blanking level and sync amplitude of trilevel sync signals. The following equipment is required for the test:

- Oscilloscope
- 75 Ω BNC cable
- 75 Ω feed-through terminator

Perform the following procedure to verify the blanking level and sync amplitude of trilevel sync signals.

1. Use the 75 Ω BNC cable and the 75 Ω feed-through terminator to connect the BLACK 2 connector on the AGL7 Genlock module to the oscilloscope CH1 input as shown in the following figure.

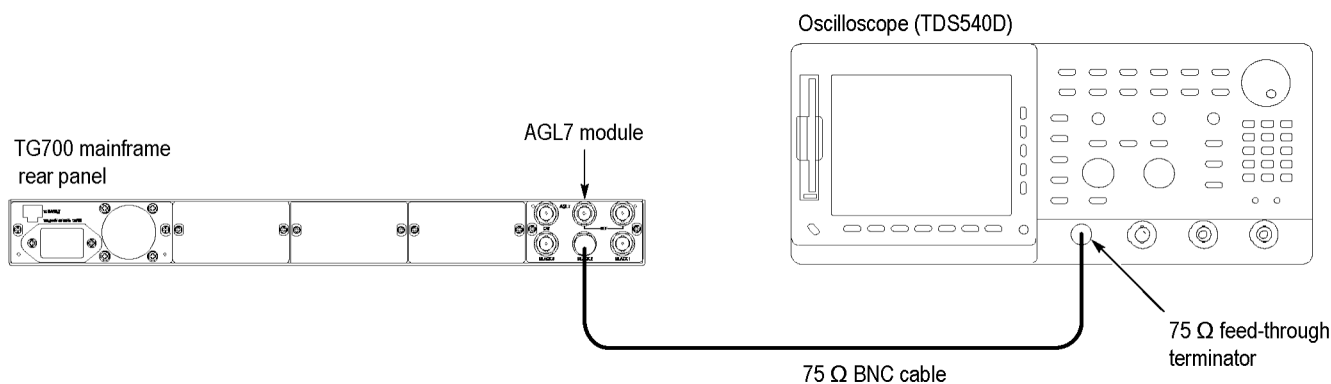

Figure 7: Equipment connection for verifying the trilevel sync outputs

2. Select the **HD SYNC (SAME AS BLACK3)** signal for BLACK 2 as follows:
 - a. Press the up (\blacktriangle) or down (\blacktriangledown) arrow button to select **SELECT OUTPUT**.
 - b. Press the left (\blacktriangleleft) or right (\blacktriangleright) arrow button to select **BLACK 2**, and then press **ENTER** to access the OUTPUT submenu.
 - c. Press the left (\blacktriangleleft) or right (\blacktriangleright) arrow button to select **HD SYNC (SAME AS BLACK3)**, and then press **ENTER**.
 - d. Press the **CANCEL** button to return the module main menu.
3. Set the oscilloscope settings as follows:

Control	Setting
Vertical	50 mV/div
Vertical offset	0 V
Horizontal	500 ns/div
Horizontal position	Center
Trig Position	50%
Trig slope	Rising Edge
Acquire menu	Average 32

4. Verify that the blanking level is within the range of +50 mV to –50 mV.
5. Change the oscilloscope vertical scale to 10mV/div.
6. Align the blanking level with the center graticule line on the oscilloscope.
7. Change the oscilloscope vertical offset to 300 mV.
8. Verify that the high level of the signal (sync amplitude plus) is within the range of +0.6 div to –0.6 div to the center graticule (except for ringing of the rising edge).
9. Change the oscilloscope vertical offset to –300 mV.
10. Verify that the low level of the signal (sync amplitude minus) is within the range of +0.6 div to –0.6 div to the center graticule (except for ringing of the falling edge).
11. Change the BNC cable connection from BLACK 2 connector to the BLACK 3 connector on the AGL7 Genlock module and repeat steps 4 through 10.

Black Burst Outputs.

This test verifies the blanking level, burst amplitude, and sync amplitude of black burst signals. The following equipment is required for the test:

- Oscilloscope
- Video measurement set
- 75 Ω feed-through terminator
- 75 Ω terminator

Perform the following procedure to verify the blanking level, burst amplitude, and sync amplitude of black burst signals.

Use the equipment connection and controls from the previous test.

1. Move the BNC cable connection from BLACK 3 connector to the BLACK 1 connector on the AGL7 Genlock module.
2. Select the **NTSC Black Burst** signal for BLACK 2 and BLACK 3 as follows:
 - a. Press the left (◀) or right (▶) arrow button to select **BLACK 2**, and then press **ENTER** to access the OUTPUT submenu.
 - b. Press the left (◀) or right (▶) arrow button to select **NTSC**, and then press **ENTER** to access the SIGNAL submenu.
 - c. Press the left (◀) or right (▶) arrow button to select **Black Burst**, and then press **ENTER**.
 - d. Press the **CANCEL** button to return the module main menu.
 - e. Press the left (◀) or right (▶) arrow button to select **BLACK 3**, and then press **ENTER** to access the OUTPUT submenu.
 - f. Press the left (◀) or right (▶) arrow button to select **BB (SAME AS BLACK2)**, and then press **ENTER**.
 - g. Press the **CANCEL** button to return the module main menu.

3. Set the oscilloscope settings as follows:

Control	Setting
Vertical	50 mV/div
Vertical offset	0 V
Horizontal	1 μ s/div
Horizontal position	Center
Trig position	10%
Acquire menu	Average 32
Measure menu	Mean
Trig type	Video
Trig standard	NTSC
Trig source	CH1
Trig polarity	Negative
Trig field	Odd Field
Trig line	2
Trig mode	MONO (2 Field)

4. Verify that the blanking level is within the range of +50 mV to –50 mV.
5. Move the BNC cable connection from the BLACK 1 connector to the BLACK 2 connector on the AGL7 Genlock module and repeat step 4.
6. Move the BNC cable connection from the BLACK 2 connector to the BLACK 3 connector on the AGL7 Genlock module and repeat step 4.
7. Move the BNC cable connection from the BLACK 3 connector to the BLACK 1 connector on the AGL7 Genlock module.
8. Disconnect the BNC cable from the 75 Ω feed-through terminator on the oscilloscope input, and then connect the BNC cable to the CHAN A connector on the video measurement set as shown in the following figure. (See Figure 8.)
9. Use the 75 Ω coaxial terminator to terminate the other loop through to the CHAN A connector on the video measurement set.

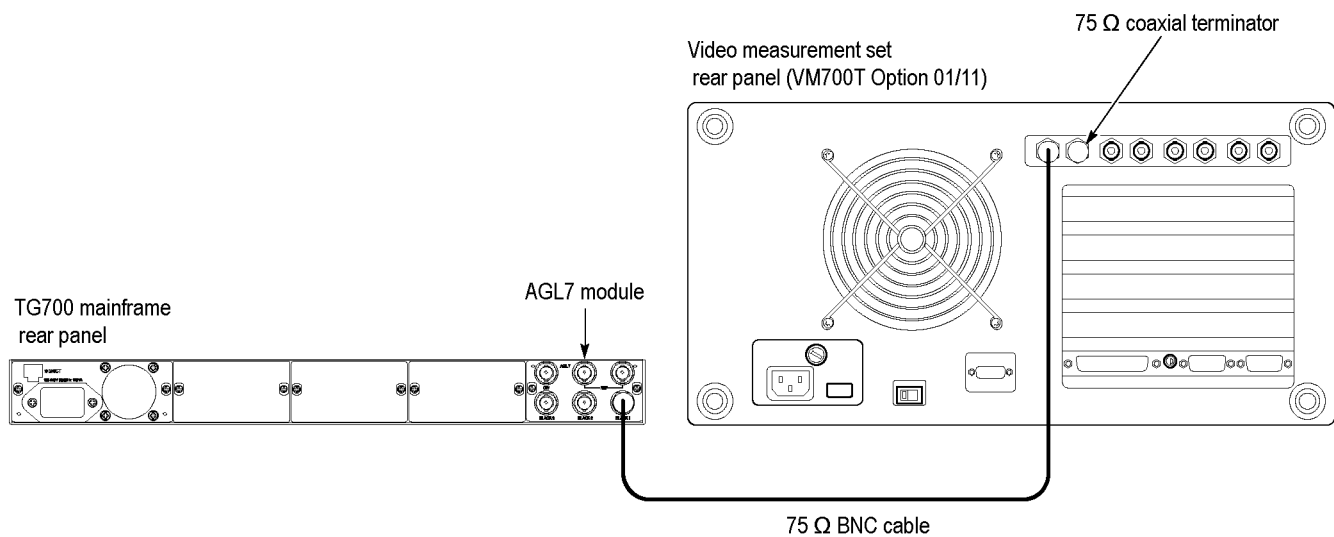

Figure 8: Equipment connection for verifying burst and sync amplitude

10. Press the **Measure** button on the video measurement set to open the Measure mode display.
11. Touch the **Mode** soft key to set the instrument to Analog mode, and then touch the **H_Timing** soft key.
12. Press the **Menu** button to display the H_Timing main menu.
13. Touch the **Average** soft key and rotate the front-panel knob to set the value to 32.
14. Touch the **RS-170A** soft key.
15. Press the **Select Line** button and rotate the front-panel knob to set the measurement line to 100 (Field=1 Line=100).
16. Verify that the burst and sync amplitude are within the range of 280.0 mV to 291.4 mV.
17. Move the BNC cable connection from the BLACK 1 connector to the BLACK 2 connector on the AGL7 Genlock module and repeat step 16.
18. Move the BNC cable connection from the BLACK 2 connector to the BLACK 3 connector on the AGL7 Genlock module and repeat step 16.

Subcarrier Frequency.

This test verifies the subcarrier frequency accuracy of black burst signals. The following equipment is required for the test:

- Frequency counter
- 75 Ω BNC cable
- 75 Ω feed-through terminator

Perform the following procedure to verify the subcarrier frequency accuracy of the black burst signals.

1. Use the 75 Ω BNC cable and the 75 Ω feed-through terminator to connect the BLACK 1 connector on the AGL7 Genlock module to the INPUT A connector on the frequency counter as shown in the following figure.

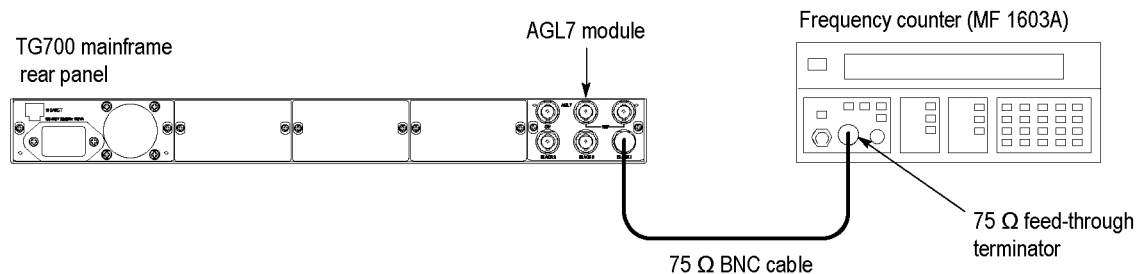

Figure 9: Equipment connection for verifying subcarrier frequency

2. Set the frequency counter to the frequency measurement mode (if necessary), and then set the Gate Time to $< 2s$.
3. Output the NTSC subcarrier calibration signal as follows:
 - a. Press and hold the **MODULE**, **FORMAT**, and **FRONT PANEL ENABLE** buttons simultaneously until **TG700 Preset** appears in the display, then release the **MODULE** and **FORMAT** buttons to restart the instrument in Factory mode.
 - b. Press the up (\blacktriangle) or down (\blacktriangledown) arrow button to select **SELECT OUTPUT**.
 - c. Press the left (\blacktriangleleft) or right (\blacktriangleright) arrow button to select **BLACK 1**, and then press **ENTER** to access the OUTPUT submenu.
 - d. Press the left (\blacktriangleleft) or right (\blacktriangleright) arrow button to select **CAL**, and then press **ENTER** to access the SIGNAL submenu.
 - e. Press the left (\blacktriangleleft) or right (\blacktriangleright) arrow button to select **NTSC Subcarrier (1Vp-p)**, and then press **ENTER**.
 - f. Press the **CANCEL** button to return the module main menu.
4. Set the frequency counter to trigger on the input, and then verify that the displayed frequency is within the range of 3.5795444 MHz to 3.5795464 MHz.

48 kHz Clock Output (Serial number J320101 and above only).

This test verifies that the 48 kHz clock signal is output correctly from the CW (48 KHz CLOCK) connector. The following equipment is required for the test:

- Oscilloscope
- 75 Ω BNC cable

Perform the following procedure to verify that the 48 kHz clock signal is output correctly from the CW (48 KHz CLOCK) connector.

1. Disconnect the power cable from the TG700 mainframe.
2. Remove the AGL7 Genlock module from the TG700 mainframe.
3. Change internal cabling to output the 48 kHz clock signal from the CW connector:
 - a. Disconnect the coaxial cable from the connector labeled **J040** on the circuit board. (See Figure 10.)
 - b. Reconnect the cable to the connector labeled **J960** on the circuit board. (See Figure 10.)

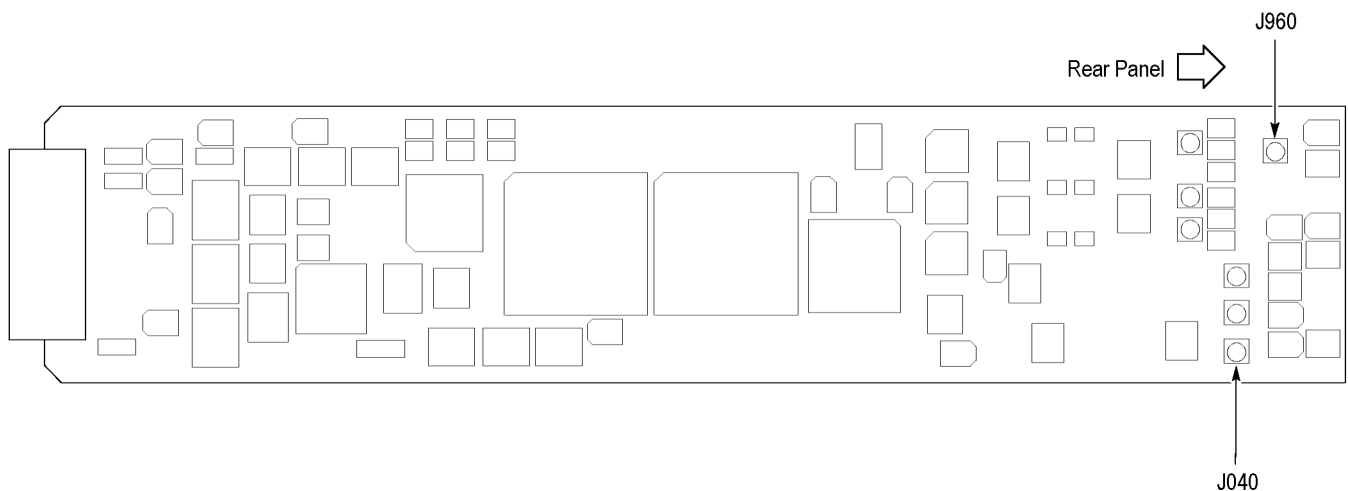

Figure 10: Location of the J040 and J960 connectors

4. Install the AGL7 Genlock module into the TG700 mainframe.
5. Connect the power cable to the TG700 mainframe.
6. Use the 75 Ω BNC cable to connect the CW (48 kHz CLOCK) connector on the AGL7 Genlock module to the oscilloscope CH1 input as shown in the following figure.

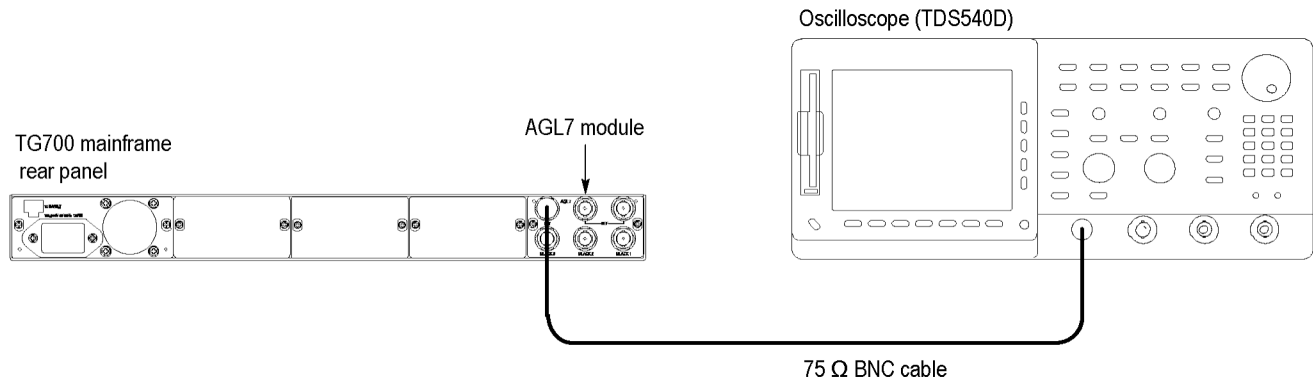

Figure 11: Equipment connection for verifying the 48 kHz clock output

7. Set the oscilloscope settings as follows:

Control	Setting
Vertical	1 V/div
Horizontal	10 μ s/div
Horizontal position	Center
Trig position	50%
Trig source	Rising Edge
Acquire menu	Sample
Input impedance	1 MW
Measure	High and Low

8. Use the oscilloscope to measure that the signal amplitude is as follows:

Low: < 0.8 V

High: > 2.1 V

This completes the AGL7 module performance verification procedure. If you require further assistance, contact your nearest Tektronix Service Center.

ATG7 Module Performance Verification

The following procedures verify the functionality of the ATG7 Analog Test Generator module.

Required Equipment The following table lists the required equipment for the following procedure.

Table 65: Required equipment for ATG7 performance verification

Item	No.	Minimum requirement	Recommended equipment
Oscilloscope	1	Bandwidth: 200 MHz or higher	Tektronix TDS540D
Video measurement set	1		Tektronix VM700T Option 01/11
75 Ω BNC cable	1	Length: 42 inches	Tektronix part number 012-0074-00
75 Ω feed-through terminator	1		Tektronix part number 011-0103-02
75 Ω coaxial terminator	1		Tektronix part number 011-0102-01

Test Record Photocopy this table and use it to record the performance test results.

Table 66: ATG7 test record

Serial Number	Cal Date	Temperature	Humidity		
Step	Function Tested	Minimum	Cal Data	Maximum	
SIGNAL Output (Tested format: NTSC)					
1.	Luminance Amplitude (Measured on 75% Color Bars signal)	707.2 mV	mV	721.0 mV	
2.	Chrominance to Luminance Gain Ratio (Measured on FCC Composite signal)	-1.0%	%	1.0%	
3.	Chrominance to Luminance Delay (Measured on FCC Composite signal)	—	ns	10 ns	
4.	Differential Phase and Gain (Measured on Modulated 5 Step signal)	Gain	—	OK	0.5%
		Phase	—	OK	0.5 °
SIGNAL Output (Tested format: PAL)					
5.	Luminance Amplitude (Measured on 75% color Bars signal)	693.0 mV	mV	707.0 mV	

Table 66: ATG7 test record (cont.)

Serial Number	Cal Date		Temperature	Humidity	
Step	Function Tested		Minimum	Cal Data	Maximum
6.	Chrominance to Luminance Gain Ratio (Measured on CCIR17 signal)		-1.0%	%	1.0%
7.	Chrominance to Luminance Delay (Measured on CCIR17 signal)		—	ns	10 ns
8.	Differential Phase and Gain (Measured on Modulated 5 Step signal)	Gain	—	OK	0.5%
		Phase	—	OK	0.5 °
9.	Luminance Linearity Error (Measured on 5 Step signal)		—		1.0%
10.	Frequency Response (to 5.0 MHz) (Measured on 100% Multiburst signal)		-1.0%	OK	1.0%
BARS Output (Tested format: PAL)					
11.	Luminance Gain (Measured on 75% color Bar Over Red signal)		693.0 mV	mV	707.0 mV
12.	Chrominance Gain (Measured on 75% color Bar Over Red signal)		650.6 mV	mV	677.0 mV
BLACK 1 and BLACK 2 Outputs					
13.	Timing Pulse Amplitude	BLACK 1 (Peak to Peak value)	900 mV	mV	1100 mV
		BLACK 2 (Peak to Peak value)	900 mV	mV	1100 mV
SIGNAL, BARS, BLACK 1, and BLACK2 Outputs (Common function)					
14.	Blanking Level	SIGNAL	-50 mV	mV	50 mV
		BARS	-50 mV	mV	50 mV
		BLACK 1	-50 mV	mV	50 mV
		BLACK 2	-50 mV	mV	50 mV

Table 66: ATG7 test record (cont.)

Serial Number	Cal Date		Temperature	Humidity	
Step	Function Tested		Minimum	Cal Data	Maximum
15.	Burst Amplitude	SIGNAL (Peak to Peak value)	280 mV	mV	291.4 mV
		BARS (Peak to Peak value)	280 mV	mV	291.4 mV
		BLACK 1 (Peak to Peak value)	280 mV	mV	291.4 mV
		BLACK 2 (Peak to Peak value)	280 mV	mV	291.4 mV
16.	Sync Amplitude	SIGNAL	280 mV	mV	291.4 mV
		BARS	280 mV	mV	291.4 mV
		BLACK 1	280 mV	mV	291.4 mV
		BLACK 2	280 mV	mV	291.4 mV

Procedures The following procedure determines if the ATG7 Analog Test Generator module is operating correctly.

Be sure you have performed the performance verification preparation before proceeding. (See page 35, *Performance Verification*.)



WARNING. *Dangerous electric shock hazards exist inside the TG700 mainframe. Only qualified service personnel should perform these procedures.*

Timing Pulse Outputs (Black 1 and Black 2).

This test verifies the pulse amplitude of the H drive signal from the BLACK 1 and BLACK 2 outputs. The following equipment is required for the test:

- Oscilloscope
- 75 Ω BNC cable
- 75 Ω feed-through terminator

Perform the following procedure to verify the pulse amplitude signal from the BLACK 1 and BLACK 2 outputs.

1. Use the 75 Ω BNC cable and the 75 Ω feed-through terminator to connect the BLACK 1 connector on the ATG7 Generator module to the oscilloscope CH1 input as shown in the following figure.

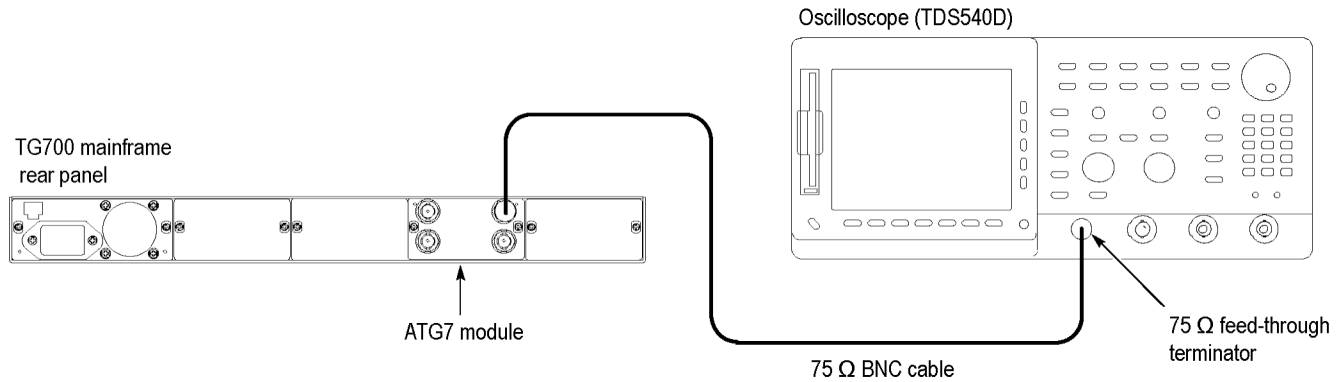

Figure 12: Equipment connection for verifying pulse amplitude

2. Recall the Factory Default preset as follows:
 - a. Press the **MODULE** button to display the TG700 main menu.
 - b. Press the up (**▲**) or down (**▼**) arrow button to select **RECALL**.
 - c. Press the left (**◀**) or right (**▶**) arrow button to select **Factory Default**.
 - d. Press **ENTER** to recall the factory default settings.
3. Select the **H Drive** signal for BLACK 1 and BLACK 2 as follows:
 - a. Press the **MODULE** button to display the ATG7 main menu.
 - b. Press the up (**▲**) or down (**▼**) arrow button to select **SELECT OUTPUT**.
 - c. Press the left (**◀**) or right (**▶**) arrow button to select **BLACK 1**, and then press **ENTER**.
 - d. Press the left (**◀**) or right (**▶**) arrow button to select **NTSC**, and then press **ENTER**.
 - e. Press the left (**◀**) or right (**▶**) arrow button to select **H Drive**, and then press **ENTER**.
 - f. Press the **CANCEL** button twice to return the module main menu.
 - g. Repeat parts b through d of this step to select the H Drive signal for BLACK 2.
4. Set the oscilloscope settings as follows:

Control	Setting
Vertical	200 mV/div
Vertical offset	0 V

Control	Setting
Horizontal	200 ns/div
Horizontal position	Center
Trig position	50%
Trig source	Rising Edge
Acquire menu	Average 32
Measure	Peak to peak

5. Verify that the pulse amplitude is within the range of 0.900 V to 1.100V.
6. Move the BNC cable from the BLACK 1 connector to the BLACK 2 connector on the ATG7 Generator module and repeat step 4.

Black Burst Outputs.

This test verifies the blanking level, burst amplitude, and sync amplitude of black burst signals. The following equipment is required for the test:

- Oscilloscope
- Video measurement set
- 75 Ω BNC cable
- 75 Ω feed-through terminator
- 75 Ω coaxial terminator

Perform the following procedure to verify the blanking level, burst amplitude, and sync amplitude of black burst signals.

Use the equipment connection and controls from the previous test.

1. Move the BNC cable from the BLACK 2 connector to the BLACK 1 connector on the ATG7 Generator module.
2. Select the **Black Burst** signal for BLACK 1, BLACK 2, and BARS as follows:
 - a. Press the **MODULE** button to display the module main menu.
 - b. Press the left (◀) or right (▶) arrow button to select **BLACK 1**, and then press **ENTER**.
 - c. Press the left (◀) or right (▶) arrow button to select **NTSC**, and then press **ENTER**.
 - d. Press the left (◀) or right (▶) arrow button to select **Black Burst**, and then press **ENTER**.
 - e. Press the **CANCEL** button twice to return the module main menu.
 - f. Repeat parts b to e of this step to select the NTSC black burst signal for BLACK 2 and BARS.
3. Select the **Black Burst** signal for SIGNAL as follows:
 - a. Press the **FORMAT** button to select **NTSC**, and then press **ENTER**.
 - b. Press the **FLAT FIELD** button to select **Black Burst**.
4. Set the oscilloscope settings as follows:

Control	Setting
Vertical	50 mV/div
Vertical offset	0 V
Horizontal	1 μ s/div
Horizontal position	Center
Trig position	10%
Acquire menu	Average 32
Measure menu	Mean
Trig type	Video
Trig standard	NTSC
Trig source	CH1
Trig polarity	Negative
Trig field	Odd Field
Trig line	2
Trig mode	MONO (2 Field)

5. Verify that the blanking level is within the range of -50 mV to $+50$ mV.
6. Move the BNC cable from the BLACK 1 connector to the BLACK 2 connector on the ATG7 Generator module and repeat step 4.

7. Move the BNC cable from the BLACK 2 connector to the SIGNAL connector on the ATG7 Generator module and repeat step 4.
8. Move the BNC cable from the SIGNAL connector to the BARS connector on the ATG7 Generator module and repeat step 4.
9. Move the BNC cable from the BARS connector to the BLACK 1 connector on the ATG7 Generator module.
10. Disconnect the BNC cable from the 75 Ω feed-through terminator on the oscilloscope input, and then connect the BNC cable to the CHAN A connector on the video measurement set as shown in the following figure.
11. Use the 75 Ω coaxial terminator to terminate the other loop through to the CHAN A connector on the video measurement set.

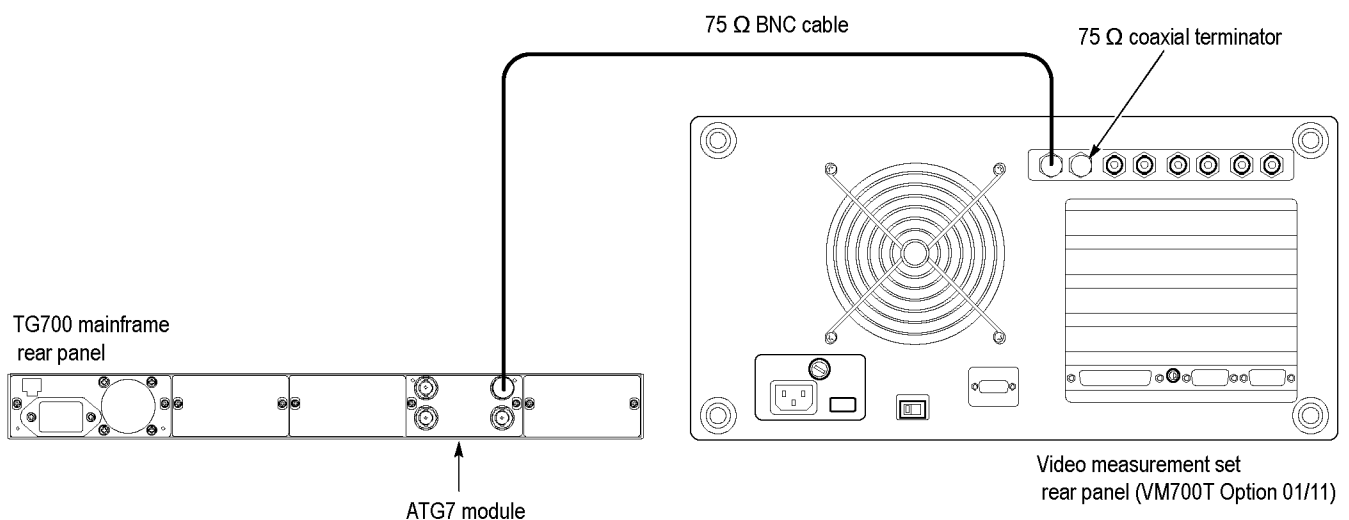

Figure 13: Equipment connection for verifying burst and sync amplitude

12. Press the **Measure** button on the video measurement set to open the Measure mode display.
13. Touch the **Mode** soft key to set the instrument to Analog mode, and then touch the **H_Timing** soft key.
14. Press the **Menu** button to display the H_Timing main menu.
15. Touch the **Average** soft key and rotate the front-panel knob to set the value to 32.
16. Touch the **RS-170A** soft key.
17. Press the **Select Line** button and rotate the front-panel knob to set the measurement line to 100 (Field=1 Line=100).
18. Verify that the burst and sync amplitude are within the range of 39.2 IRE to 40.8 IRE.

19. Move the BNC cable from the BLACK 1 connector to the BLACK 2 connector on the ATG7 Generator module and repeat step 16.
20. Move the BNC cable from the BLACK 2 connector to the SIGNAL connector on the ATG7 Generator module and repeat step 16.
21. Move the BNC cable from the SIGNAL connector to the BARS connector on the ATG7 Generator module and repeat step 16.

Luminance and Chrominance Gain (BARS Output).

This test verifies the luminance and chrominance gain of the 75% color bar over red signal from the BARS output. The following equipment is required for the test:

- Video measurement set
- 75 Ω feed-through terminator
- 75 Ω coaxial terminator

Perform the following procedure to verify the luminance and chrominance gain of the 75% color bar over red signal from the BARS output.

Use the equipment connection and controls from the previous test.

1. Select the **75% Color Bar Over Red** signal for BARS as follows:
 - a. Press the **MODULE** button to display the ATG7 main menu.
 - b. Press the up (▲) or down (▼) arrow button to select **SELECT OUTPUT**.
 - c. Press the left (◀) or right (▶) arrow button to select **BARS**, and then press **ENTER**.
 - d. Press the left (◀) or right (▶) arrow button to select **PAL**, and then press **ENTER**.
 - e. Press the left (◀) or right (▶) arrow button to select **75% Color Bar Over Red**, and then press **ENTER**.
2. Press the **Measure** button on the video measurement set to open the Measure mode display.
3. Touch the **Video Standard** soft key to recognize the applied video signal as PAL.
4. In the Measure mode display, touch the **Color Bar** soft key to open the Color Bar measurement display.
5. Press the **Menu** button to display the Color Bar main menu.
6. Touch the **Average** soft key and rotate the front-panel knob to set the value to 256.
7. Press the **Select Line** button and rotate the front-panel knob to set the measurement line to 100 (Field=1 Line=100).
8. Verify that the luminance gain (level) is within the range of 693.0 mV to 707.0 mV.
9. Verify that the chrominance gain (level) is within the range of 650.6 mV to 677.0 mV. Note that the chrominance gain is measured by Red.

Luminance Amplitude (SIGNAL Output).

This test verifies the luminance amplitude of the 75% color bars signal (for NTSC) and the 75% color bars signal (for PAL) from the SIGNAL output.

- Video measurement set
- 75 Ω feed-through terminator
- 75 Ω coaxial terminator

Perform the following procedure to verify the luminance amplitude of the 75% color bars signal (for NTSC) and the 75% color bars signal (for PAL) from the SIGNAL output.

Use the equipment connection and controls from the previous test.

NTSC Format.

1. Move the BNC cable from the BARS connector to the SIGNAL connector on the ATG7 Generator module.
2. Select the **75% Color Bars** signal for SIGNAL as follows:
 - a. Press the **MODULE** button to display the ATG7 main menu.
 - b. Press the **FORMAT** button to select **NTSC**, and then press **ENTER**.
 - c. Press the **COLOR BAR** button to select **75% Color Bars**.
3. Press the **Measure** button on the video measurement set to open the Measure mode display.
4. Touch the **Video Standard** soft key to recognize the applied video signal as NTSC.
5. Press the **Menu** button, and then touch the **Average** soft key and rotate the front-panel knob to set the value to 256.
6. Touch the **Average** soft key and rotate the front-panel knob to set the value to 256.
7. Press the **Select Line** button and rotate the front-panel knob to set the measurement line to 100 (Field=1 Line=100).
8. Verify that the luminance gain (level) is within the range of 707.2 mV to 721.0 mV.

PAL Format.

1. Select the **75% Color Bars** signal for SIGNAL as follows:
 - a. Press the **FORMAT** button to select **PAL**, and then press **ENTER**.
 - b. Press the **COLOR BAR** button to select **75% Color Bars**.
2. Press the **Measure** button on the video measurement set to open the Measure mode display.
3. Touch the **Video Standard** soft key to recognize the applied video signal as PAL.
4. In the Measure mode display, touch the **Color Bar** soft key to open the Color Bar measurement display.
5. Press the **Menu** button, and then touch the **Average** soft key and rotate the front-panel knob to set the value to 256.
6. Press the **Select Line** button and rotate the front-panel knob to set the measurement line to 100 (Field=1 Line=100).
7. Verify that the luminance gain (level) is within the range of 693.0 mV to 707.0 mV.

Chrominance to Luminance Gain and Delay (SIGNAL Output). This test verifies the chrominance to luminance gain and delay of the FCC composite signal (for NTSC) and the CCIR17 signal (for PAL) from the SIGNAL output.

- Video measurement set
- 75 Ω feed-through terminator
- 75 Ω coaxial terminator

Perform the following procedure to verify the chrominance to luminance gain and delay of the FCC composite signal (for NTSC) and the CCIR17 signal (for PAL) from the SIGNAL output.

Use the equipment connection and controls from the previous test.

NTSC Format.

1. Select the **FCC Composite** signal for SIGNAL as follows:
 - a. Press the **FORMAT** button to select **NTSC**, and then press **ENTER**.
 - b. Press the **OTHER** button to select **FCC Composite**.
2. Press the **Measure** button on the video measurement set to open the Measure mode display.
3. Touch the **Video Standard** soft key to recognize the applied video signal as NTSC.
4. In the Measure mode display, touch the **ChromLum GainDelay** soft key to open the chrominance to luminance gain and delay measurement display.
5. Press the **Menu** button, and then touch the **Average** soft key and rotate the front-panel knob to set the value to 256.
6. Press the **Select Line** button and rotate the front-panel knob to set the measurement line to 100 (Field=1 Line=100).
7. Verify that the chrominance gain is 100% \pm 1%.
8. Verify that the chrominance delay is within the range of -10 ns to + 10 ns.

PAL Format.

9. Select the **CCIR 17** signal for SIGNAL as follows:
 - a. Press the **FORMAT** button to select **PAL**, and then press **ENTER**.
 - b. Press the **OTHER** button to select CCIR 17.
10. Press the **Measure** button on the video measurement set to open the Measure mode display.
11. Touch the **Video Standard** soft key to recognize the applied video signal as PAL.
12. In the Measure mode display, touch the **ChromLum GainDelay** soft key to open the chrominance to luminance gain and delay measurement display.
13. Press the **Menu** button, and then touch the **Average** soft key and rotate the front-panel knob to set the value to 256.
14. Press the **Select Line** button and rotate the front-panel knob to set the measurement line to 100 (Field=1 Line=100).
15. Verify that the chrominance gain is 100% \pm 1%.
16. Verify that the chrominance delay is within the range of -10 ns to $+10$ ns.

Differential Phase and Gain (SIGNAL Output). This test verifies the differential phase and gain of the modulated 5 step signal from the SIGNAL output.

- Video measurement set
- 75 Ω feed-through terminator
- 75 Ω coaxial terminator

Perform the following procedure to verify the differential phase and gain of the modulated 5 step signal from the SIGNAL output.

Use the equipment connection and controls from the previous test.

NTSC Format.

1. Select the **Modulated 5 Step** signal for SIGNAL as follows:
 - a. Press the **FORMAT** button to select **NTSC**, and then press **ENTER**.
 - b. Press the **LINEARITY** button to select **Modulated 5 Step**.
2. Press the **Measure** button on the video measurement set to open the Measure mode display.
3. Touch the **Video Standard** soft key to recognize the applied video signal as NTSC.
4. In the Measure mode display, touch the **DGDP** soft key to open the differential gain and phase measurement display.
5. Press the **Menu** button, and then touch the **Average** soft key and rotate the front-panel knob to set the value to 256.
6. Press the **Select Line** button and rotate the front-panel knob to set the measurement line to 100 (Field=1 Line=100).
7. Verify that the p-p/max value of the differential gain is less than or equal to 0.5%.
8. Verify that the peak to peak value of the differential phase is less than or equal to 0.5 degree.

PAL Format.

9. Press the **FORMAT** button to select **PAL**, and then press **ENTER**.
10. Press the **Measure** button on the video measurement set to open the Measure mode display.
11. Touch the **Video Standard** soft key to recognize the applied video signal as PAL.
12. In the Measure mode display, touch the **DGDP** soft key to open the differential gain and phase measurement display.
13. Press the **Menu** button, and then touch the **Average** soft key and rotate the front-panel knob to set the value to 256.
14. Press the **Select Line** button and rotate the front-panel knob to set the measurement line to 100 (Field=1 Line=100).
15. Verify that the p-p/max value of the differential gain is less than or equal to 0.5%.
16. Verify that the peak to peak value of the differential phase is less than or equal to 0.5 degree.

Luminance Linearity Error (SIGNAL Output). This verifies the luminance linearity error of the 5 step signal from the SIGNAL output.

- Video measurement set
- 75 Ω feed-through terminator
- 75 Ω coaxial terminator

Perform the following procedure to verify the luminance linearity error of the 5 step signal from the SIGNAL output.

Use the equipment connection and controls from the previous test.

1. Press the **LINEARITY** button to select **5 Step**.
2. Press the **Measure** button on the video measurement set to open the Measure mode display.
3. In the Measure mode display, touch the **Luminance Non Linearity** soft key to open the luminance non linearity measurement display.
4. Press the **Menu** button, and then touch the **Average** soft key and rotate the front-panel knob to set the value to 256.
5. Press the **Select Line** button and rotate the front-panel knob to set the measurement line to 100 (Field=1 Line=100).
6. Verify that p-p value of the luminance non linearity is within the range of -1.0% to 1.0%.

Frequency Response (SIGNAL Output). This verifies the frequency response of the multiburst signal from the SIGNAL output.

- Video measurement set
- 75 Ω feed-through terminator
- 75 Ω coaxial terminator

Perform the following procedure to verify the frequency response of the multiburst signal from the SIGNAL output.

Use the equipment connection and controls from the previous test.

1. Press the **MULTIBURST** button to select **100% Multiburst**.
2. Press the **Measure** button on the video measurement set to open the Measure mode display.
3. In the Measure mode display, touch the **Multiburst** soft key to open the multiburst measurement display.
4. Press the **Menu** button, and then touch the **Average** soft key and rotate the front-panel knob to set the value to 256.
5. Press the **Select Line** button and rotate the front-panel knob to set the measurement line to 100 (Field=1 Line=100).
6. Verify that the amplitude is within the range of -0.08 dB to $+0.08$ dB (0.5 MHz to 4.8 MHz).

This completes the ATG7 module performance verification procedure. If you require further assistance, contact your nearest Tektronix Service Center.

AVG7 Module Performance Verification

The following procedures verify the functionality of the AVG7 Analog Video Generator module.

Required Equipment The following table lists the required equipment for the following procedure.

Table 67: Required equipment for AVG7 performance verification

Item	No.	Minimum requirement	Recommended equipment
Oscilloscope	1	Bandwidth: 1 GHz or higher	Tektronix TDS784D
Video measurement set	1		Tektronix VM700T Option 01/11
Digital multimeter	1	5 1/2 digits	FLUKE 8842A
Peak detector amplifier	1		Tektronix part number 015-0408-00 and TM500 series power supply
Peak detector head	1		Tektronix part number 015-0413-00
Color picture monitor	1		SONY BVMD14H5J and BKM129X
Test signal generator	1		Tektronix ATG7
75 Ω BNC cable	3	Length: 72 inches	Tektronix part number 012-0159-01
75 Ω BNC cable	1	5C-2V, 1 m	Canare DH5C01-S-SA
75 Ω feed-through termination	1		Tektronix part number 011-0103-02
75 Ω coaxial termination	1		Tektronix part number 011-0102-01
75 Ω signal adapter	2	Bandwidth: 1 GHz Amplitude precision: -3 dB	Tektronix AMT75
BNC T connector	1		Tektronix part number 103-0030-00

Table 67: Required equipment for AVG7 performance verification (cont.)

Item	No.	Minimum requirement	Recommended equipment
BNC female-to-dual banana adapter	1		Tektronix part number 103-0090-00
BNC female-to-female connector	1		Canare BCJ-J

Test Record Photocopy this table and use it to record the performance test results.

Table 68: AVG7 test record

Serial number	Cal date		Temperature	Humidity	
Step	Function Tested		Minimum	Cal data	Maximum
1.	Absolute Amplitude	CH 1 Output	693.0 mV	mV	707.0 mV
		CH 2 Output	693.0 mV	mV	707.0 mV
		CH 3 Output	693.0 mV	mV	707.0 mV
2.	Channel Gain Matching (Relative to CH 1)	CH 2 Output	—	%	0.5%
		CH 3 Output	—	%	0.5%
3.	DC Offset	CH 1 Output (GBR)	-10 mV	mV	10 mV
		CH 2 Output (GBR)	-10 mV	mV	10 mV
		CH 3 Output (GBR)	-10 mV	mV	10 mV
		CH 2 Output (YPbPr)	-10 mV	mV	10 mV
		CH 3 Output (YPbPr)	-10 mV	mV	10 mV
4.	Channel-to-Channel Delay (Relative to CH 1)	CH 2 Output	-1.0 ns	ns	1 ns
		CH 3 Output	-1.0 ns	ns	1 ns
5.	Frequency Response (Measured on DAC test signal)	CH 1 Output (Peak value from 0.5 MHz to 5 MHz)	-3.5 mV	mV	3.5 mV
		CH 2 Output (Peak value from 0.5 MHz to 5 MHz)	-3.5 mV	mV	3.5 mV
		CH 3 Output (Peak value from 0.5 MHz to 5 MHz)	-3.5 mV	mV	3.5 mV
6.	Chrominance to Luminance Gain Ratio (Measured on DAC test signal)	CH 1 Output \leq 1.0%	-1.0%	%	1.0%
		CH 2 Output \leq 1.0%	-1.0%	%	1.0%
		CH 3 Output \leq 1.0%	-1.0%	%	1.0%

Table 68: AVG7 test record (cont.)

Serial number	Cal date		Temperature	Humidity	
Step	Function Tested		Minimum	Cal data	Maximum
7.	Line Time Distortion (Measured on NTSC: FCC Composite signal)	CH 1 Output $\leq 0.5\%$ (Peak to Peak value)	—	%	0.5%
		CH 2 Output $\leq 0.5\%$ (Peak to Peak value)	—	%	0.5%
		CH 3 Output $\leq 0.5\%$ (Peak to Peak value)	—	%	0.5%
8.	Field Time Distortion (Measured on Field Square Wave signal of all composite outputs)	CH 1 Output $\leq 0.5\%$ (Peak to Peak value)	—	%	0.5%
		CH 2 Output $\leq 0.5\%$ (Peak to Peak value)	—	%	0.5%
		CH 3 Output $\leq 0.5\%$ (Peak to Peak value)	—	%	0.5%
9.	K Factor 2T5 Pulse (Measured on CCIR17 & FCC Composite signal)	CH 1 Output (K-2T) $\leq 0.5\%$ (Peak to Peak value)	—	%	0.5%
		CH 2 Output (K-2T) $\leq 0.5\%$ (Peak to Peak value)	—	%	0.5%
		CH 3 Output (K-2T) $\leq 0.5\%$ (Peak to Peak value)	—	%	0.5%
		CH 1 Output (K-PB) $\leq 0.5\%$ (Peak to Peak value)	—	%	0.5%
		CH 2 Output (K-PB) $\leq 0.5\%$ (Peak to Peak value)	—	%	0.5%
		CH 3 Output (K-PB) $\leq 0.5\%$ (Peak to Peak value)	—	%	0.5%

Table 68: AVG7 test record (cont.)

Serial number	Cal date		Temperature	Humidity	
Step	Function Tested		Minimum	Cal data	Maximum
10.	Differential Phase and Gain (Measured on Modulated 5 Step signal)	CH 1 Output (DG) \leq 0.5%	—	%	0.5%
		CH 2 Output (DG) \leq 0.5%	—	%	0.5%
		CH 3 Output (DG) \leq 0.5%	—	%	0.5%
		CH 1 Output (DP) \leq 0.5°	—	°	0.5°
		CH 2 Output (DP) \leq 0.5°	—	°	0.5°
		CH 3 Output (DP) \leq 0.5°	—	°	0.5°

Procedures The following procedure determines if the AVG7 Analog Video Generator module is operating correctly.

Be sure you have performed the performance verification preparation before proceeding. (See page 35, *Performance Verification*.)



WARNING. *Dangerous electric shock hazards exist inside the TG700 mainframe. Only qualified service personnel should perform these procedures.*

DC Offset and Amplitude Error.

This test verifies the DC offset and amplitude error of the channel outputs. The following equipment is required for the test:

- Digital multimeter
- BNC female-to-dual banana adapter
- BNC T connector
- 75 Ω coaxial termination
- 75 Ω BNC cable

Perform the following procedure to verify the output offset and gain of the channel outputs:

1. Use the 75 Ω BNC cable, BNC T connector, 75 Ω coaxial termination, and BNC female-to-dual banana adapter to connect the upper CH 1 connector on the AVG7 Generator module to the INPUT connector on the digital multimeter as shown in the following figure.

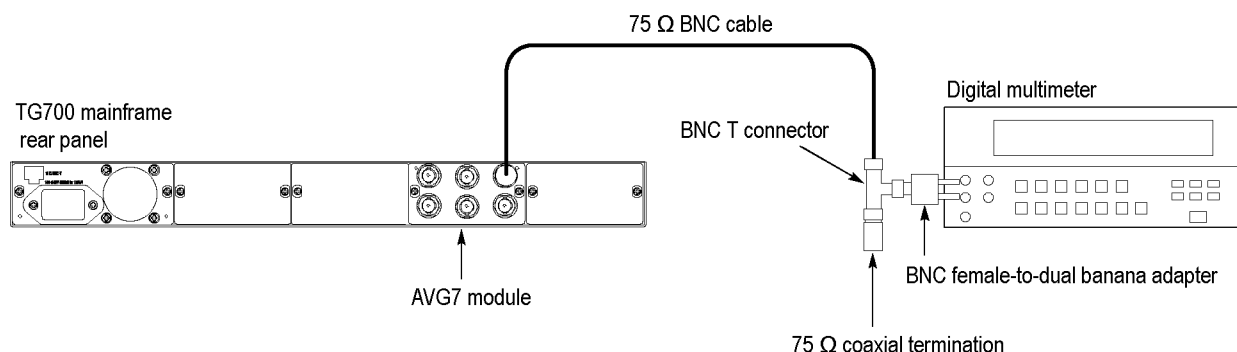

Figure 14: Equipment connection for verifying the DC offset and amplitude error

2. Press the **MODULE**, **FORMAT**, and **FRONT PANEL ENABLE** buttons simultaneously, and then release the **MODULE** and **FORMAT** buttons to restart the instrument in Factory mode. Continue holding down the **FRONT PANEL ENABLE** button until the “TG700 start up with Factory Mode.” message appears.
3. Select the DAC Gain (GBR): 0 mV calibration signal as follows:
 - a. Press the **MODULE** button to display the **AVG7** main menu.
 - b. Press the up (**▲**) or down (**▼**) arrow button to select **CALIBRATION**.
 - c. Press the left (**◀**) or right (**▶**) arrow button to select **DAC Gain (GBR)**, and then press **ENTER**.
 - d. Press the left (**◀**) or right (**▶**) arrow button to select **0mV**, and then press **ENTER**.
4. Verify that the output offset is within the range of -10 mV to 10 mV. Note this value as **CH1_DC0**.
5. Move the BNC cable from the upper CH 1 connector to the upper CH 2 connector on the AVG7 Generator module.
6. Verify that the output offset is within the range of -10 mV to 10 mV. Note this value as **CH2_DC0**.
7. Move the BNC cable from the upper CH 2 connector to the upper CH 3 connector on the AVG7 Generator module.
8. Verify that the output offset is within the range of -10 mV to 10 mV. Note this value as **CH3_DC0**.

9. Move the BNC cable from the upper CH 3 connector to the upper CH 1 connector on the AVG7 Generator module.
10. Press the left (◀) or right (▶) arrow button to select **700.397mV**, and then press **ENTER**.
11. Read the value on the digital multimeter, and note this value as **CH1_DC1**.
12. **CH1_DC1CH1_DC0 CH1_V1 CH1_DC0 CH1_V1**
13. Move the BNC cable from the upper CH 1 connector to the upper CH 2 connector on the AVG7 Generator module.
14. Read the value on the digital multimeter, and note this value as **CH2_DC1**.
15. **CH2_DC1CH2_DC0 CH2_V1 CH2_DC0 CH2_V1**
16. Move the BNC cable from the upper CH 2 connector to the upper CH 3 connector on the AVG7 Generator module.
17. Read the value on the digital multimeter, and note this value as **CH3_DC1**.
18. Verify that **CH3_DC1–CH3_DC0** is within the range of 693.0 mV to 707.0 mV. Note this value as **CH3_V1**.
19. Verify that the amplitude errors of the CH 2 and CH 3 outputs meet the following relationships:
$$\text{CH 2 amplitude error} = ((\text{CH2_V1}/\text{CH1_V1})-1)\times 100 \leq \pm 0.5\%$$
$$\text{CH 3 amplitude error} = ((\text{CH3_V1}/\text{CH1_V1})-1)\times 100 \leq \pm 0.5\%$$
20. Move the BNC cable from the upper CH 3 connector to the upper CH 2 connector on the AVG7 Generator module.
21. Select the **DAC Gain (YPbPr) : 0 mV** calibration signal for CH 2 and CH 3 as follows:
 - a. Press the **CANCEL** button to display the **CALIBRATION** menu.
 - b. Press the left (◀) or right (▶) arrow button to select **DAC Gain (YPbPr)**, and then press **ENTER**.
 - c. Press the left (◀) or right (▶) arrow button to select **0mV**, and then press **ENTER**.
22. Verify that the output offset is within the range of –10 mV to 10 mV.
23. Move the BNC cable from the upper CH 2 connector to the upper CH 3 connector on the AVG7 Generator module.
24. Verify that the output offset is within the range of –10 mV to 10 mV.

Channel-to-Channel Delay.

This test verifies the time delay among the channel outputs. The following equipment is required for the test:

- Oscilloscope
- Test signal generator
- Two 75 Ω signal adapters
- 75 Ω feed-through termination
- Three 75 Ω BNC cables

Perform the following procedure to verify the time delay among the channel outputs:

1. Use the 75 Ω BNC cable and the 75 Ω signal adapter to connect the upper CH 1 connector on the AVG7 Generator module to the CH 1 input connector on the oscilloscope as shown in the following figure. (See Figure 15.)
2. Use the 75 Ω BNC cable and the 75 Ω signal adapter to connect the upper CH 2 connector on the AVG7 Generator module to the CH 2 input connector on the oscilloscope as shown in the following figure. (See Figure 15.)
3. Use the 75 Ω BNC cable and the 75 Ω feed-through termination to connect the BLACK 1 connector on the test signal generator to the CH 3 input connector on the oscilloscope as shown in the following figure.

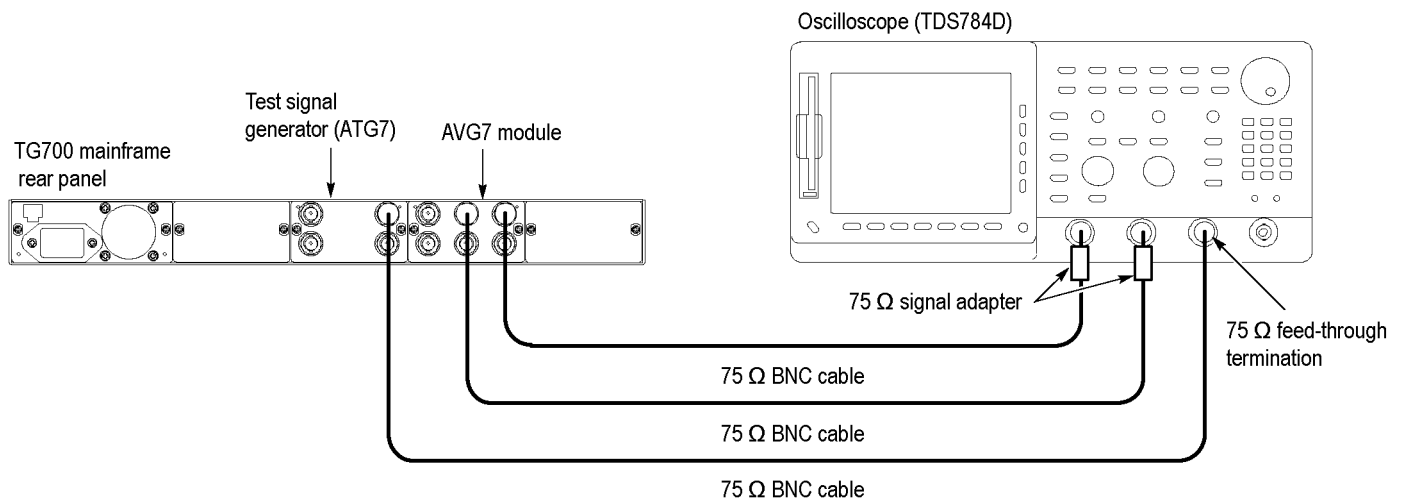

Figure 15: Equipment connection for verifying the channel-to-channel delay

4. Set the oscilloscope settings as follows:

Control	Setting
Vertical	CH 1 and CH 2: 5 mV/div, CH 3: 1.00 V/div

Control	Setting
Bandwidth	250 MHz (CH 1 and CH 2)
Vertical offset	0 mV (CH 1 and CH 2)
Horizontal scale	20 μ s/div
Horizontal delay time	50 ns/div
Delayed runs time	6.468 μ s (Delayed Only)
Trigger position	50%
Trigger source	CH 3
Trigger type	Edge
Acquire menu	Average 64 Repetitive Signal: OFF
CH 3 waveform	OFF

5. Use the **CH 2 Vertical Position** knob on the oscilloscope to align the CH 2 trace to the CH 1 trace with no signal input.
6. Press the **MODULE**, **FORMAT**, and **FRONT PANEL ENABLE** buttons simultaneously, and then release the **MODULE** and **FORMAT** buttons to restart the instrument in Factory mode. Continue holding down the **FRONT PANEL ENABLE** button until the “TG700 start up with Factory Mode.” message appears.
7. Set the test signal generator (ATG7 module) settings as follows:

Control	Setting
Output selection	BLACK 1
Signal format	NTSC
Test signal	Field Reference

8. Select the **Field Square Wave** signal as follows:
 - a. Press the **MODULE** button to display the **AVG7** main menu.
 - b. Press the **FORMAT** button to select **NTSC**, and then press **ENTER**.
 - c. Press the **FLAT FIELD** button to select **Field Square Wave**.
9. Use the **CH 1 Vertical Position** and **CH 2 Vertical Position** knobs on the oscilloscope to align the blanking level of the CH 1 signal to the blanking level of the CH 2 signal at the center of the screen.
10. Change the oscilloscope settings as follows:

Control	Setting
Vertical offset	-143 mV (CH 1 and CH 2)
Horizontal delay time	2.00 ns/Div

Control	Setting
Delay runs time	6.224 μ s

11. Use the vertical cursors to perform the timing measurement and verify that the time delay between the CH 1 waveform and the CH 2 waveform is within 1 ns.
12. Move the BNC cable from the upper CH 2 connector to the upper CH 3 connector on the AVG7 Generator module.
13. Return the oscilloscope settings as follows:

Control	Setting
Vertical offset	0 mV (CH 1 and CH 2)
Delay runs time	6.468 μ s (Delayed Only)

14. Repeat steps 9 through 11.

Frequency Response.

This test verifies the frequency response of the DAC test signal from the CH 1, CH 2, and CH 3 outputs. The following equipment is required for the test:

- Oscilloscope
- Peak detector
- Peak detector head
- Test signal generator
- 75 Ω feed-through termination
- Three 75 Ω BNC cables

Perform the following procedure to verify the frequency response of the DAC test signal from the CH 1, CH 2, and CH 3 outputs:

1. Use the two 75 Ω BNC cables, peak detector head, and BNC female-to-female connector to connect the upper CH 1 connector on the AVG7 Generator module to the +INPUT connector on the peak detector amplifier as shown in the following figure. (See Figure 16.)
2. Use the 75 Ω BNC cable to connect the OUTPUT connector on the peak detector amplifier to the CH 1 input connector on the oscilloscope as shown in the following figure. (See Figure 16.)
3. Use the 75 Ω BNC cable and the 75 Ω feed-through termination to connect the BLACK 1 connector on the test signal generator to the CH 2 input connector on the oscilloscope as shown in the following figure.

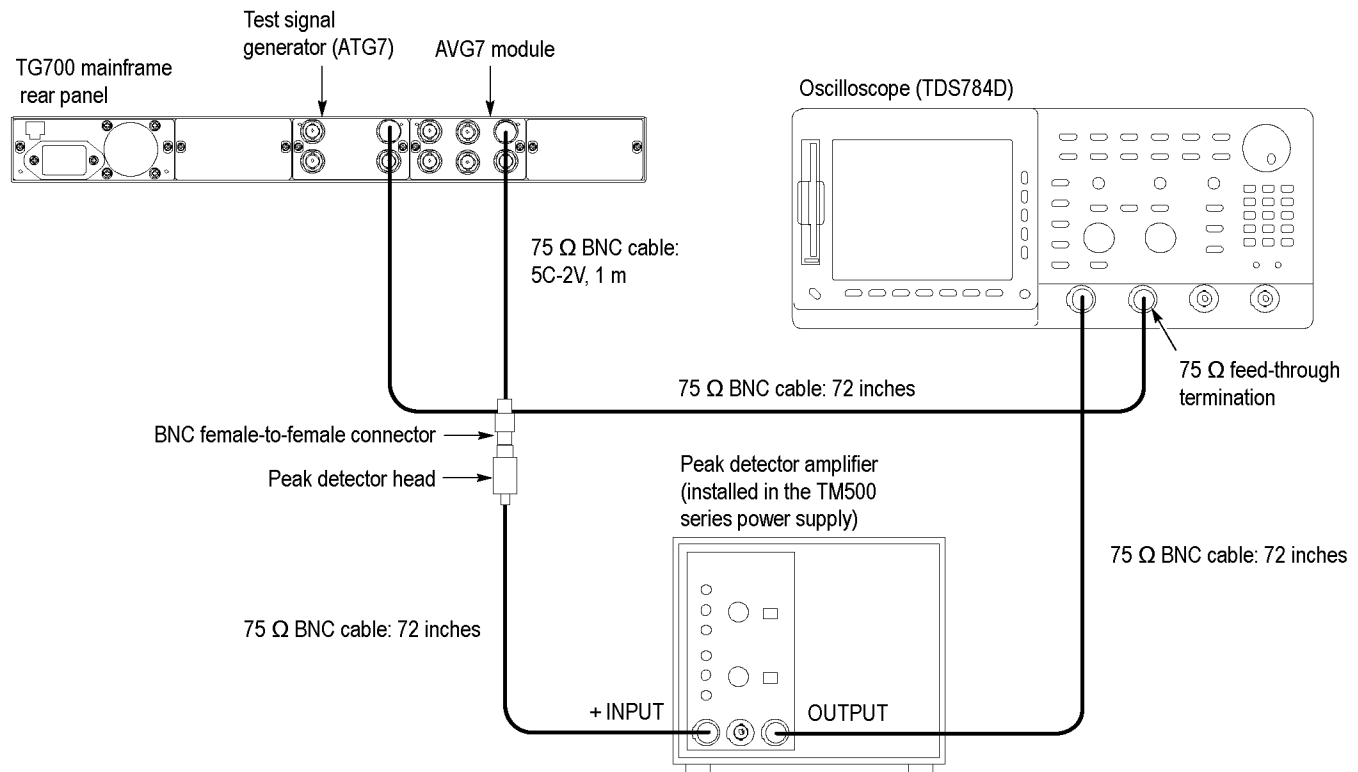

Figure 16: Equipment connection for verifying the frequency response

4. Set the oscilloscope settings as follows:

Control	Setting
Vertical scale	CH 1: 2 mV/div, CH 2: 1.00 V/div
Bandwidth	20 MHz (CH 1)
Horizontal scale	2 ms/div
Trigger position	10%
Trigger source	CH 2
Trigger type	Edge

Control	Setting
Acquire menu	Peak Detect

5. Press the **MODULE**, **FORMAT**, and **FRONT PANEL ENABLE** buttons simultaneously, and then release the **MODULE** and **FORMAT** buttons to restart the instrument in Factory mode. Continue holding down the **FRONT PANEL ENABLE** button until the “TG700 start up with Factory Mode.” message appears.
6. Set the test signal generator (ATG7 module) settings as follows:

Control	Setting
Output selection	BLACK 1
Signal format	NTSC
Test signal	Field Reference

7. Select the 525 GBR signal format as follows:
 - a. Press the **MODULE** button to display the AVG7 main menu.
 - b. Press the **FORMAT** button to select **525 GBR**, and then press **ENTER**.
 - c. Press the **COLOR BAR** button.
8. Select the DAC Test calibration signal as follows:
 - a. Press the up (▲) or down (▼) arrow button to select **CALIBRATION**.
 - b. Press the left (◀) or right (▶) arrow button to select **DAC Test**, and then press **ENTER**.
 - c. Press **ENTER** again to confirm the signal output.
9. Select the Sync ON All Channels mode as follows:
 - a. Press the up (▲) or down (▼) arrow button to select **VIDEO**, and then press **ENTER** button to access the VIDEO submenu.
 - b. Press the up (▲) or down (▼) arrow button to select **GBR SYNC**.
 - c. Press the left (◀) or right (▶) arrow button to select **Sync ON All Channels**, and then press **ENTER**.
10. Turn the LEVEL knob on the peak detector amplifier so that the green LED light.
11. Verify that the differences between the maximum amplitude and minimum amplitude from 500 kHz to 5 MHz are less than or equal to 3.5 mV. (See Figure 17.)

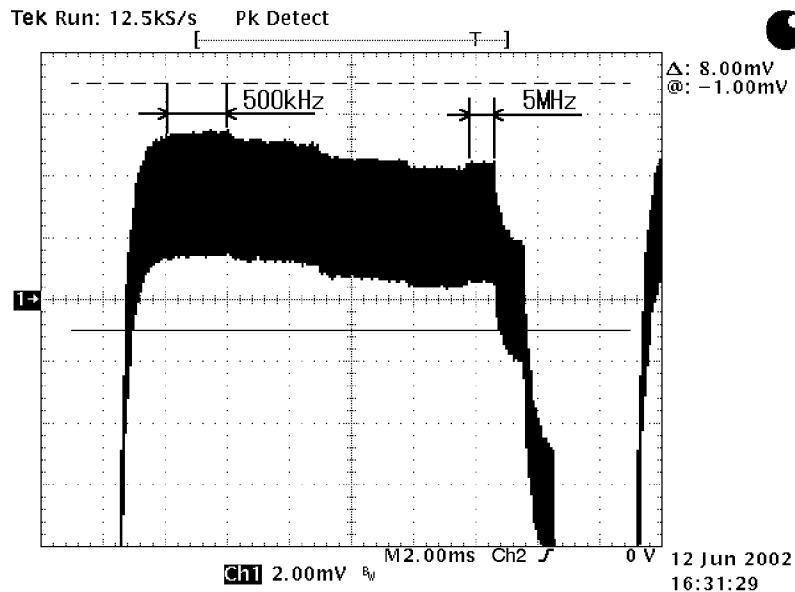

Figure 17: Verifying the signal amplitudes from 500 kHz to 5 MHz

12. Move the peak detector head from the upper CH 1 connector to the upper CH 2 connector on the AVG7 Generator module and repeat steps 10 and 11.
13. Move the peak detector head from the upper CH 2 connector to the upper CH 3 connector on the AVG7 Generator module and repeat steps 10 and 11.
14. Move the peak detector head from the upper CH 3 connector to the lower CH 1 connector on the AVG7 Generator module and repeat steps 10 and 11.
15. Move the peak detector head from the lower CH 1 connector to the lower CH 2 connector on the AVG7 Generator module and repeat steps 10 and 11.
16. Move the peak detector head from the lower CH 2 connector to the lower CH 3 connector on the AVG7 Generator module and repeat steps 10 and 11.

Line Time Distortion.

This test verifies the line time distortion of the FCC composite signal from the CH 1, CH 2, and CH 3 outputs. The following equipment is required for the test:

- Video measurement set
- 75 Ω feed-through termination
- 75 Ω coaxial termination

Perform the following procedure to verify the line time distortion of the field square wave signal from the CH 1, CH 2, and CH 3 outputs:

1. Use the 75 Ω BNC cable to connect the upper CH 1 connector on the AVG7 Generator module to the CHAN A connector on the video measurement set as shown in the following figure.

2. Use the 75 Ω coaxial termination to terminate the other loopthrough to the CHAN A connector on the video measurement set.

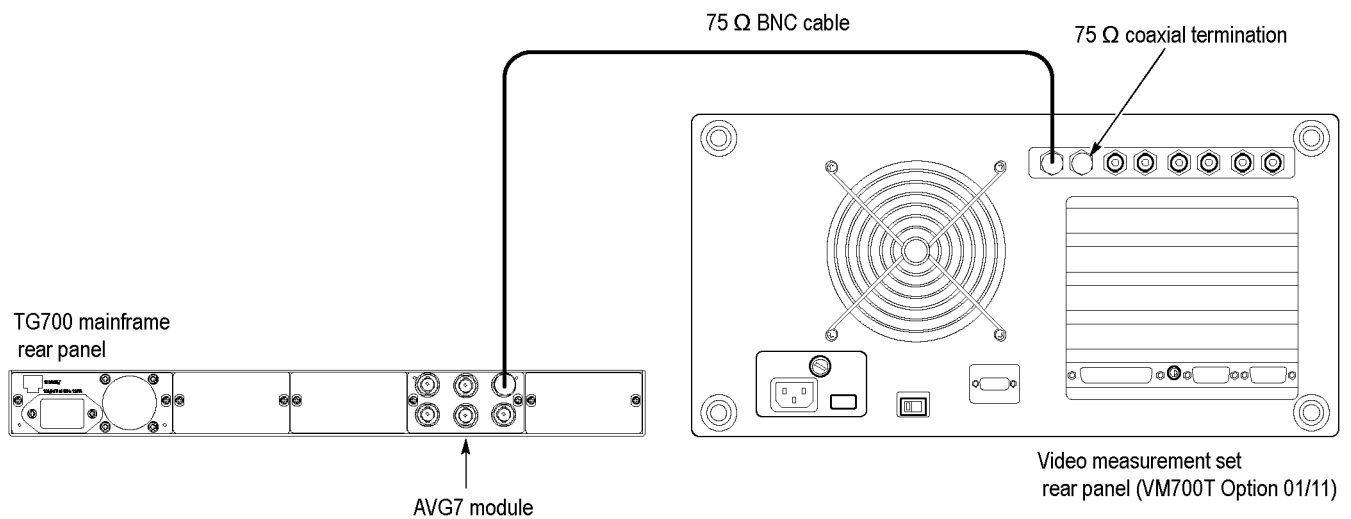

Figure 18: Equipment connection for verifying the line time distortion

3. Select the FCC Composite signal as follows:
 - a. Press the **MODULE** button to display the AVG7 main menu.
 - b. Press the **FORMAT** button to select **NTSC**, and then press **ENTER**.
 - c. Press the **OTHER** button to select **FCC Composite**.
4. Press the **Measure** button on the video measurement set to open the Measure mode display.
5. Touch the **Video Standard** soft key to recognize the applied video signal as NTSC.
6. In the Measure mode display, touch the **Bar LineTime** to open the Bar & LineTime measurement display.
7. Press the **Menu** button to display the Bar & LineTime main menu.
8. Touch the **Average** soft key and rotate the front-panel knob to set the value to 256.
9. Press the **Select Line** button and rotate the front-panel knob to set the measurement line to 17 (Field=1 Line=17).
10. Verify that the line time distortion is less than or equal to 0.5%.
11. Move the BNC cable from the upper CH 1 connector to the upper CH 2 connector on the AVG7 Generator module and repeat step 10.
12. Move the BNC cable from the upper CH 2 connector to the upper CH 3 connector on the AVG7 Generator module and repeat step 10.

Field Time Distortion.

This test verifies the field time distortion of the field square wave signal from the CH 1, CH 2, and CH 3 connectors. The following equipment is required for the test:

- Video measurement set
- 75 Ω feed-through termination
- 75 Ω coaxial termination

Perform the following procedure to verify the field time distortion of the field square wave signal from the CH 1, CH 2, and CH 3 outputs:

Use the equipment connection and controls from the previous test.

1. Move the BNC cable from the upper CH 3 connector to the upper CH 1 connector on the AVG7 Generator module.
2. Select the Field Square Wave signal as follows:
 - a. Press the **MODULE** button to display the AVG7 main menu.
 - b. Press the **FORMAT** button to select **NTSC**, and then press **ENTER**.
 - c. Press the **FLAT FIELD** button to select **Field Square Wave**.
3. Press the **Measure** button on the video measurement set to open the Measure mode display.
4. Touch the **Video Standard** soft key to recognize the applied video signal as NTSC.
5. In the Measure mode display, touch the **Two Field** to open the Two Field measurement display.
6. Press the **Menu** button to display the Two Field main menu.
7. Touch the **Average** soft key and rotate the front-panel knob to set the value to 256.
8. Press the **Select Line** button and rotate the front-panel knob to set the measurement line to 17 (Field=1 Line=17).
9. Verify that the field time distortion is less than or equal to 0.5%.
10. Move the BNC cable from the upper CH 1 connector to the upper CH 2 connector on the AVG7 Generator module and repeat step 9.
11. Move the BNC cable from the upper CH 2 connector to the upper CH 3 connector on the AVG7 Generator module and repeat step 9.

K Factor.

This test verifies the K factor of the CCIR17 signal from the CH 1, CH 2, and CH 3 outputs. The following equipment is required for the test:

- Video measurement set
- 75 Ω feed-through termination
- 75 Ω coaxial termination

Perform the following procedure to verify the K factor of the CCIR17 signal from the CH 1, CH 2, and CH 3 outputs:

Use the equipment connection and controls from the previous test.

1. Move the BNC cable from the upper CH 3 connector to the upper CH 1 connector on the AVG7 Generator module.
2. Select the CCIR17 signal as follows:
 - a. Press the **MODULE** button to display the AVG7 main menu.
 - b. Press the **FORMAT** button to select **Pal 1**, and then press **ENTER**.
 - c. Press the **OTHER** button to select **CCIR17**.
3. Press the **Measure** button on the video measurement set to open the Measure mode display.
4. Touch the **Video Standard** soft key to recognize the applied video signal as PAL.
5. In the Measure mode display, touch the **K_Factor** to open the K Factor measurement display.
6. Press the **Menu** button to display the K Factor main menu.
7. Touch the **Average** soft key and rotate the front-panel knob to set the value to 256.
8. Press the **Select Line** button and rotate the front-panel knob to set the measurement line to 17 (Field=1 Line=17).
9. Verify that the K-2T value and K-PB value are within the range of -0.5% to $+0.5\%$.
10. Move the BNC cable from the upper CH 1 connector to the upper CH 2 connector on the AVG7 Generator module and repeat step 9.
11. Move the BNC cable from the upper CH 2 connector to the upper CH 3 connector on the AVG7 Generator module and repeat step 9.

Differential Phase and Gain.

This test verifies the differential phase and gain of the modulated 5 step signal from the CH 1, CH 2, and CH 3 outputs. The following equipment is required for the test:

- Video measurement set
- 75 Ω feed-through termination
- 75 Ω coaxial termination

Perform the following procedure to verify the differential phase and gain of the modulated 5 step signal from the CH 1, CH 2, and CH 3 outputs:

Use the equipment connection and controls from the previous test.

1. Move the BNC cable from the upper CH 3 connector to the upper CH 1 connector on the AVG7 Generator module.
2. Select the Modulated 5 Step signal as follows:
 - a. Press the **FORMAT** button to select **NTSC**, and then press **ENTER**.
 - b. Press the **LINEARITY** button to select **Modulated 5 Step**.
3. Select the CH1/2/3: Composites video configuration of the AVG7 Generator module as follows:
 - a. Press the up (▲) or down (▼) arrow button to select **CONFIGURATION**, and then press **ENTER** to access the CONFIGURATION submenu.
 - b. Press the left (◀) or right (▶) arrow button to select **CH1/2/3: Composites**, and then press **ENTER**.
4. Set the Y video signal to off as follows:
 - a. Press the up (▲) or down (▼) arrow button to select **VIDEO:Y**.
 - b. Press the left (◀) or right (▶) arrow button to select **OFF**, and then press **ENTER**.
5. Press the **Measure** button on the video measurement set to open the Measure mode display.
6. Touch the **Video Standard** soft key to recognize the applied video signal as NTSC.
7. In the Measure mode display, touch the **DGDP** soft key to open the differential gain and phase measurement display.
8. Press the **Menu** button, and then touch the **Average** soft key and rotate the front-panel knob to set the value to 256.
9. Touch the **Acquire** soft key to access the Acquire submenu, and then make the following settings:

Control	Setting
Auto Scan	OFF
Manual Steps	5
Ref Packet	15.2 m Sec
1 st Step	19.3 m Sec
Last Step	51.3 m Sec
Measure Cycle	10
Block Mode	ON
Block Mode Start	F1 21
Block Lines	11
Block Step	24

10. Touch the **Reference** soft key to access the Reference submenu, and then touch the **Store (1) Reference**.
11. Touch the **Relative to Ref.** soft key to access the Relative to Reference submenu, and then touch the **Use (1) Reference**.
12. Verify that the current Differential Gain value (p-p/max) and Differential Phase value (peak to peak) are less than or equal to 0.02%.
13. Set the **Y** video signal to on as follows:
 - a. Press the up (▲) or down (▼) arrow button to select **VIDEO:Y**.
 - b. Press the left (◀) or right (▶) arrow button to select **ON**, and then press **ENTER**.
14. Verify that the p-p/max value of the differential gain is less than or equal to 0.5%.
15. Verify that the peak to peak value of the differential phase is less than or equal to 0.5 degree.
16. Move the BNC cable from the upper CH 1 connector to the upper CH 2 connector on the AVG7 Generator module and repeat steps 14 and 15.
17. Move the BNC cable from the upper CH 2 connector to the upper CH 3 connector on the AVG7 Generator module and repeat steps 14 and 15.
18. Move the BNC cable from the upper CH 3 connector to the upper CH 1 connector on the AVG7 Generator module.
19. Select the Modulated 5 Step signal in PAL format as follows:
 - a. Press the **FORMAT** button to select **Pal 1** or **Pal 2**, and then press **ENTER**.
 - b. Press the **LINEARITY** button to select **Modulated 5 Step**.
20. Set the **Y** video signal to off as follows:
 - a. Press the up (▲) or down (▼) arrow button to select **VIDEO:Y**.
 - b. Press the left (◀) or right (▶) arrow button to select **OFF**, and then press **ENTER**.
21. Press the **Measure** button on the video measurement set to open the Measure mode display.
22. Touch the **Video Standard** soft key to recognize the applied video signal as PAL.
23. In the Measure mode display, touch the **DGDP** soft key to open the differential gain and phase measurement display.
24. Press the **Menu** button, and then touch the **Average** soft key and rotate the front-panel knob to set the value to 256.

25. Touch the **Acquire** soft key to access the Acquire submenu, and then make the following settings:

Control	Setting
Auto Scan	OFF
Manual Steps	5
Ref Packet	14.5 m Sec
1 st Step	18.8 m Sec
Last Step	51.3 m Sec
Measure Cycle	10
Block Mode	ON
Block Mode Start	F1 23
Block Lines	12
Block Step	26

26. Repeat steps 10 through 17.

Color Bars Signal Check.

This test verifies that the 75% color bars signal is normally output from all of the channels. The following equipment is required for the test:

- Color picture monitor
- Three 75 Ω BNC cables
- Three 75 Ω coaxial termination

Perform the following procedure to verify that the 75% color bars signal is normally output from all of the channels.

1. Use the 75 Ω BNC cable to connect the upper CH 1 connector on the AVG7 Generator module to the Y/G IN connector on the color picture monitor as shown in the following figure.
2. Use the 75 Ω BNC cable to connect the upper CH 2 connector on the AVG7 Generator module to the P_B/B IN connector on the color picture monitor as shown in the following figure.
3. Use the 75 Ω BNC cable to connect the upper CH 3 connector on the AVG7 Generator module to the P_R/R IN connector on the color picture monitor as shown in the following figure.
4. Use the 75 Ω coaxial termination to terminate the Y/G OUT, P_B/B OUT, and P_R/R OUT connectors on the color picture monitor.

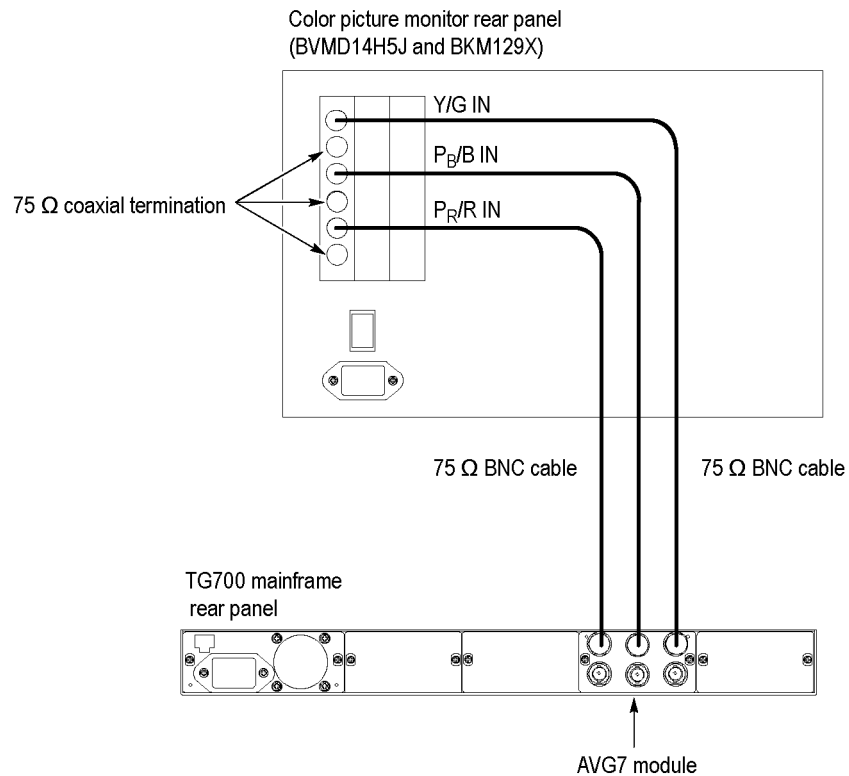

Figure 19: Equipment connection for checking the color bars signal

5. Set the display setting of the color picture monitor to the GBR mode.
6. Select the 75% Color Bars signal as follows:
 - a. Press the **MODULE** button to display the AVG7 main menu.
 - b. Press the **FORMAT** button to select **525 GBR**, and then press **ENTER**.
 - c. Press the **COLOR BAR** button to select **75% Color Bars**.
7. Select the Sync ON All Channels mode as follows:
 - a. Press the up (▲) or down (▼) arrow button to select **VIDEO**, and then press **ENTER** button to access the VIDEO submenu.
 - b. Press the up (▲) or down (▼) arrow button to select **GBR SYNC**.
 - c. Press the left (◀) or right (▶) arrow button to select **Sync ON All Channels**, and then press **ENTER**.
8. Verify that the color bars signal is displayed normally.
9. Move the BNC cable from the upper CH 1 connector to the lower CH 1 connector, from the upper CH2 connector to the lower CH 2 connector, and from the upper CH 3 connector to the lower CH 3 connector on the AVG7 Generator module and repeat step 8.

This completes the AVG7 module performance verification procedure. If you require further assistance, contact your nearest Tektronix Service Center.

AWVG7 Module Performance Verification

The following procedures verify the functionality of the AWVG7 Analog Wideband Video Generator module.

Required Equipment The following table lists the required equipment for the following procedure.

Table 69: Required equipment for AWVG7 performance verification

Item	No.	Minimum requirement	Recommended equipment
Oscilloscope	1	Bandwidth: 1 GHz or higher	Tektronix TDS784D
Digital multimeter	1	5 1/2 digits	FLUKE 8842A
Peak detector amplifier	1		Tektronix part number 015-0408-00 and TM500 series power supply
Peak detector head	1		Tektronix part number 015-0413-00
Color picture monitor	1		SONY BVMD14H5J and BKM129X
Test signal generator	1		Tektronix ATG7
75 Ω BNC cable	2	Length: 42 inches	Tektronix part number 012-0074-00
75 Ω BNC cable	1	5C-2V, 1 m	Canare DH5C01-S-SA
75 Ω feed-through termination	1		Tektronix part number 011-0103-02
75 Ω coaxial termination	3		Tektronix part number 011-0102-01
75 Ω signal adapter	1	Bandwidth: 1 GHz Amplitude precision: -3 dB	Tektronix AMT75
BNC T connector	1		Tektronix part number 103-0030-00
BNC female-to-dual banana adapter	1		Tektronix part number 103-0090-00
BNC female-to-female connector	1		Canare BCJ-J

Test Record Photocopy this table and use it to record the performance test results.

Table 70: AWVG7 test record

Serial Number	Cal Date	Temperature	Humidity	
Step	Function Tested	Minimum	Cal Data	Maximum
Tested Format: 1080 59.94i GBR				

Table 70: AWWG7 test record (cont.)

Serial Number	Cal Date		Temperature	Humidity	
Step	Function Tested		Minimum	Cal Data	Maximum
1.	Absolute Amplitude	CH 1 Output	693.0 mV	mV	707.0 mV
		CH 2 Output	693.0 mV	mV	707.0 mV
		CH 3 Output	693.0 mV	mV	707.0 mV
2.	Channel Gain Matching (Relative to CH 1)	CH 2 Output	-0.5%	%	0.5%
		CH 3 Output	-0.5%	%	0.5%
3.	DC Offset	CH 1 Output (GBR)	-10 mV	mV	10 mV
		CH 2 Output (GBR)	-10 mV	mV	10 mV
		CH 3 Output (GBR)	-10 mV	mV	10 mV
		CH 2 Output (YPbPr)	-10 mV	mV	10 mV
		CH 3 Output (YPbPr)	-10 mV	mV	10 mV
4.	Frequency Response (Measured on DAC Test Signal)	CH 1 Output (Peak value to 20 MHz)	-7.0 mV	mV	7.0 mV
		CH 1 Output (Peak value to 28 MHz)	-14.0 mV	mV	14.0 mV
		CH 1 Output (Peak value to 30 MHz)	-21.0 mV	mV	21.0 mV
		CH 2 Output (Peak value to 20 MHz)	-7.0 mV	mV	7.0 mV
		CH 2 Output (Peak value to 28 MHz)	-14.0 mV	mV	14.0 mV
		CH 2 Output (Peak value to 30 MHz)	-21.0 mV	mV	21.0 mV
		CH 3 Output (Peak value to 20 MHz)	-7.0 mV	mV	7.0 mV
		CH 3 Output (Peak value to 28 MHz)	-14.0 mV	mV	14.0 mV
		CH 3 Output (Peak value to 30 MHz)	-21.0 mV	mV	21.0 mV
5.	Line Time Distortion (Measured on 100% Flat Field signal)	CH 1 Output \leq 0.5% (Peak to Peak value)	—	%	0.5%
		CH 2 Output \leq 0.5% (Peak to Peak value)	—	%	0.5%
		CH 3 Output \leq 0.5% (Peak to Peak value)	—	%	0.5%

Table 70: AWVG7 test record (cont.)

Serial Number	Cal Date		Temperature	Humidity	
Step	Function Tested		Minimum	Cal Data	Maximum
6.	Field Time Distortion (Measured on 100% Flat Field signal)	CH 1 Output \leq 0.5% (Peak to Peak value)	—	%	0.5%
		CH 2 Output \leq 0.5% (Peak to Peak value)	—	%	0.5%
		CH 3 Output \leq 0.5% (Peak to Peak value)	—	%	0.5%

Procedures The following procedure determines if the AWVG7 Analog Wideband Video Generator module is operating correctly.

Be sure you have performed the performance verification preparation before proceeding. (See page 35, *Performance Verification*.)



WARNING. *Dangerous electric shock hazards exist inside the TG700 mainframe. Only qualified service personnel should perform these procedures.*

DC Offset and Amplitude Error.

This test verifies the DC offset and amplitude error of the channel outputs. The following equipment is required for the test:

- Digital multimeter
- BNC female-to-dual banana adapter
- BNC T connector
- 75 Ω coaxial termination
- 75 Ω BNC cable

Perform the following procedure to verify the DC offset and amplitude error of the channel outputs:

1. Use the 75 Ω BNC cable, BNC T connector, 75 Ω coaxial termination, and BNC female-to-dual banana adapter to connect the upper CH 1 connector on the AWVG7 Generator module to the INPUT connector on the digital multimeter as shown in the following figure.

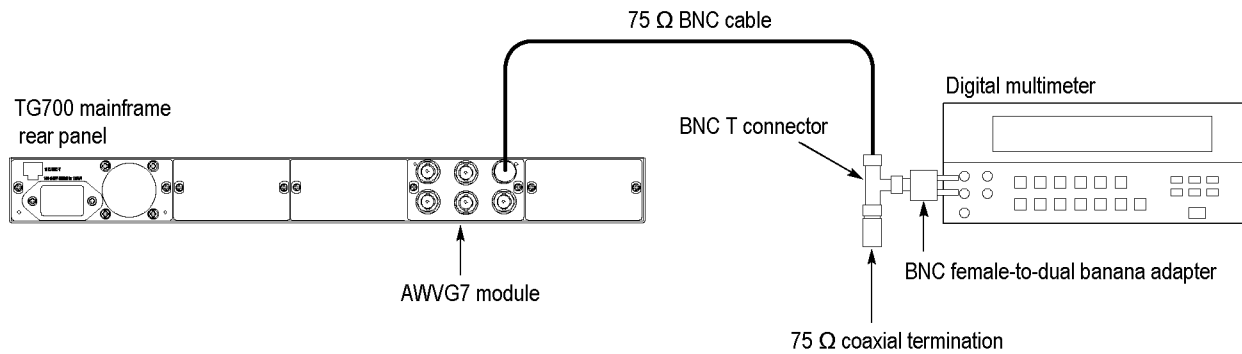

Figure 20: Equipment connection for verifying the DC offset and amplitude error

2. Press the **MODULE**, **FORMAT**, and **FRONT PANEL ENABLE** buttons simultaneously, and then release the **MODULE** and **FORMAT** buttons to restart the instrument in Factory mode. Continue holding down the **FRONT PANEL ENABLE** button until the “TG700 start up with Factory Mode.” message appears.
3. Select the DAC Gain (GBR): 0 mV calibration signal as follows:
 - a. Press the **MODULE** button to display the **AWVG7** main menu.
 - b. Press the up (**▲**) or down (**▼**) arrow button to select **CALIBRATION**.
 - c. Press the left (**◀**) or right (**▶**) arrow button to select **DAC Gain (GBR)**, and then press **ENTER**.
 - d. Press the left (**◀**) or right (**▶**) arrow button to select **0mV**, and then press **ENTER**.
4. Verify that the output offset is within the range of -10 mV to 10 mV. Note this value as **CH1_DC0**.
5. Move the BNC cable from the upper CH 1 connector to the upper CH 2 connector on the AWVG7 Generator module.
6. Verify that the output offset is within the range of -10 mV to 10 mV. Note this value as **CH2_DC0**.
7. Move the BNC cable from the upper CH 2 connector to the upper CH 3 connector on the AWVG7 Generator module.
8. Verify that the output offset is within the range of -10 mV to 10 mV. Note this value as **CH3_DC0**.
9. Move the BNC cable from the upper CH 3 connector to the upper CH 1 connector on the AWVG7 Generator module.
10. Press the left (**◀**) or right (**▶**) arrow button to select **700.397mV**, and then press **ENTER**.

11. Read the value on the digital multimeter, and then note this value as **CH1_DC1**.
12. Verify that **CH1_DC1–CH1_DC0** is within the range of 693.0 mV to 707.0 mV. Note this value as **CH1_V1**.
13. Move the BNC cable from the upper CH 1 connector to the upper CH 2 connector on the AWVG7 Generator module.
14. Read the value on the digital multimeter, and then note this value as **CH2_DC1**.
15. Verify that **CH2_DC1–CH2_DC0** is within the range of 693.0 mV to 707.0 mV. Note this value as **CH2_V1**.
16. Move the BNC cable from the upper CH 2 connector to the upper CH 3 connector on the AWVG7 Generator module.
17. Read the value on the digital multimeter, and then note this value as **CH3_DC1**.
18. **CH3_DC1CH3_DC0 CH3_V1 CH3_DC0 CH3_V1**
19. Verify that the amplitude errors of the CH 2 and CH 3 outputs meet the following relationships:

$$\text{CH 2 amplitude error} = ((\text{CH2_V1}/\text{CH1_V1})-1) \times 100 \leq \pm 0.5\%$$

$$\text{CH 3 amplitude error} = ((\text{CH3_V1}/\text{CH1_V1})-1) \times 100 \leq \pm 0.5\%$$
20. Move the BNC cable from the upper CH 3 connector to the upper CH 2 connector on the AWVG7 Generator module.
21. Select the **DAC Gain (YPbPr) : 0 mV** calibration signal for CH 2 and CH 3 as follows:
 - a. Press the **CANCEL** button to display the **CALIBRATION** menu.
 - b. Press the left (◀) or right (▶) arrow button to select **DAC Gain (YPbPr)**, and then press **ENTER**.
 - c. Press the left (◀) or right (▶) arrow button to select **0mV**, and then press **ENTER**.
22. Verify that the output offset is within the range of –10 mV to 10 mV.
23. Move the BNC cable from the upper CH 2 connector to the upper CH 3 connector on the AWVG7 Generator module.
24. Verify that the output offset is within the range of –10 mV to 10 mV.

Frequency Response.

This test verifies the frequency response of the DAC test signal from the CH 1, CH 2, and CH 3 outputs. The following equipment is required for the test:

- Oscilloscope
- Peak detector amplifier
- Peak detector head
- Two 75 Ω BNC cables

Perform the following procedure to verify the frequency response of the DAC test signal from the CH 1, CH 2 and CH 3 outputs:

1. Use the two 75 Ω BNC cables, the peak detector head, and BNC female-to-female connector to connect the upper CH 1 connector on the AWVG7 Generator module to the +INPUT connector on the peak detector amplifier as shown in the following figure.
2. Use the 75 Ω BNC cable to connect the OUTPUT connector on the peak detector amplifier to the CH 1 input connector on the oscilloscope as shown in the following figure. (See Figure 21.)
3. Set the oscilloscope settings as follows:

Control	Setting
Vertical scale	CH 1: 5 mV/div
Bandwidth	250 MHz
Horizontal scale	5 ms/div
Trigger position	10%
Trigger source	CH 1
Trigger type	Edge
Trigger level	-50 mV
Acquire menu	Average 64

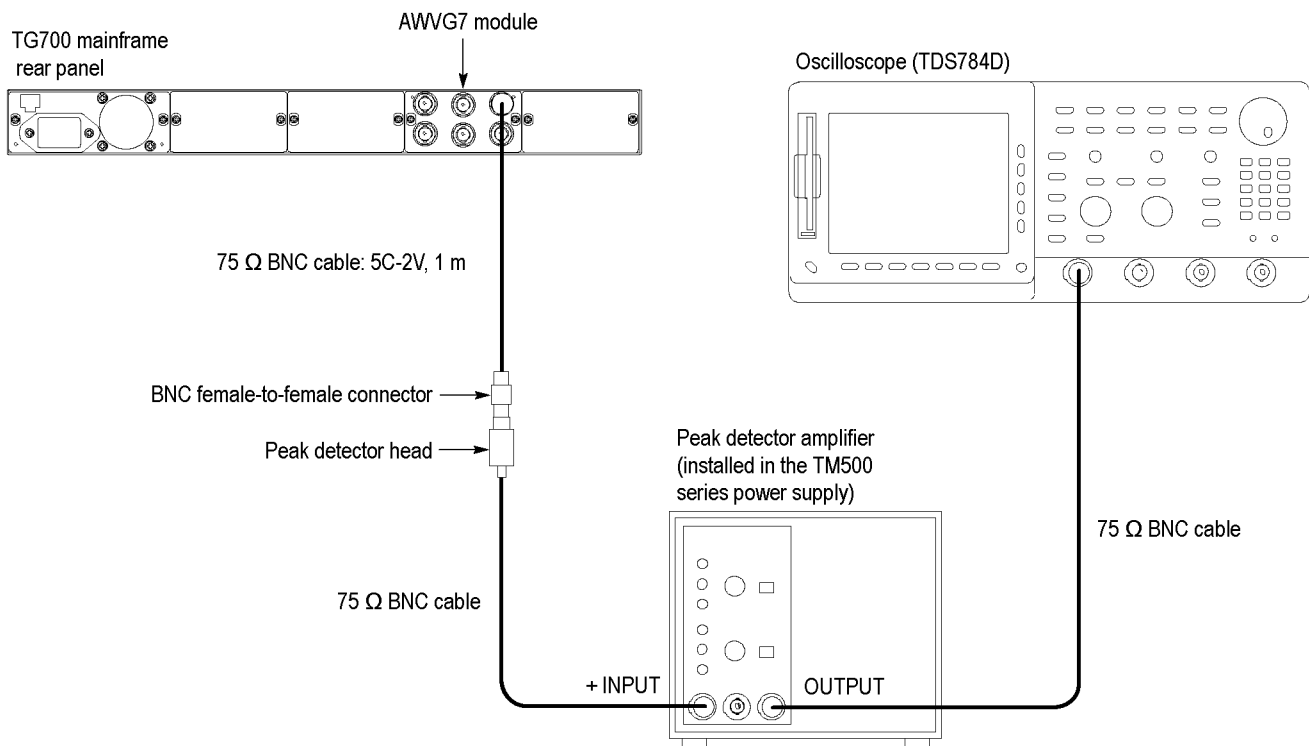

Figure 21: Equipment connection for verifying the frequency response

4. Press the **MODULE**, **FORMAT**, and **FRONT PANEL ENABLE** buttons simultaneously, and then release the **MODULE** and **FORMAT** buttons to restart the instrument in Factory mode. Continue holding down the **FRONT PANEL ENABLE** button until the “TG700 start up with Factory Mode.” message appears.
5. Select the DAC Test calibration signal as follows:
 - a. Press the **MODULE** button to display the **AWVG7** main menu.
 - b. Press the up (**▲**) or down (**▼**) arrow button to select **CALIBRATION**.
 - c. Press the left (**◀**) or right (**▶**) arrow button to select **DAC Test**, and then press **ENTER**.
 - d. Press **ENTER** again to confirm the signal output.
6. Turn the **LEVEL** knob on the peak detector amplifier so that the green LED lights.
7. Verify that the differences between the maximum amplitude and the minimum amplitude from 500 kHz to 20 MHz are less than or equal to 7 mV. (See Figure 22.)

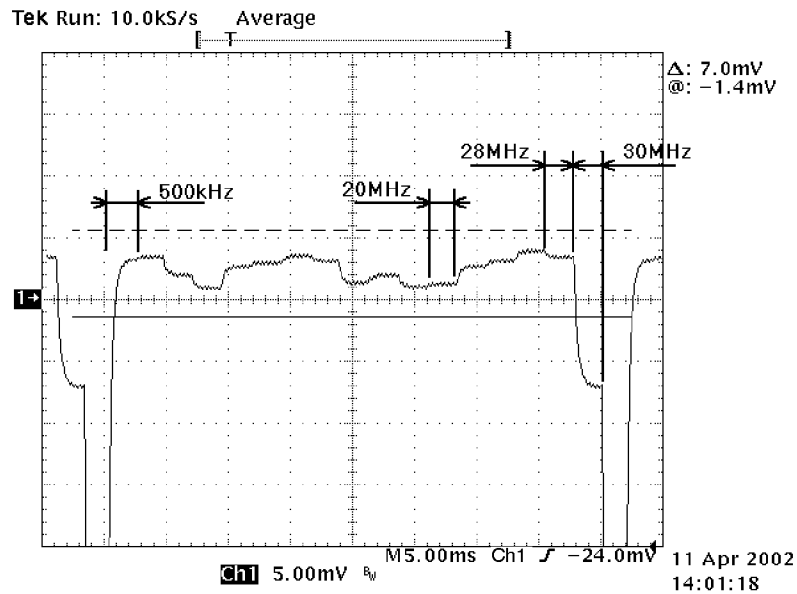

Figure 22: Verifying the signal amplitudes

8. Verify that the differences between the maximum amplitude and the minimum amplitude from 500 kHz to 28 MHz are less than or equal to 14 mV. (See Figure 22.)
9. Verify that the differences between the maximum amplitude and the minimum amplitude from 500 kHz to 30 MHz are less than or equal to 21 mV. (See Figure 22.)
10. Move the peak detector head from the upper CH 1 connector to the upper CH 2 connector on the AWVG7 Generator module and repeat steps 11 through 9.
11. Move the peak detector head from the upper CH 2 connector to the upper CH 3 connector on the AWVG7 Generator module and repeat steps 11 through 9.

Field Time Distortion.

This test verifies the field time distortion of the 100% flat field signal from the CH 1, CH 2, and CH 3 outputs. The following equipment is required for the test:

- Oscilloscope
- Test signal generator
- 75 Ω signal adapters
- 75 Ω feed-through terminator
- Two 75 Ω BNC cables

Perform the following procedure to verify the field time distortion of the 100% flat field signal:

1. Use the 75 Ω BNC cable and the 75 Ω signal adapter to connect the upper CH 1 connector on the AWVG7 Generator module to the CH 1 input connector on the oscilloscope as shown in the following figure.
2. Use the 75 Ω BNC cable and the 75 Ω feed-through termination to connect the BLACK 1 connector on the test signal generator to the CH 2 input connector on the oscilloscope as shown in the following figure.

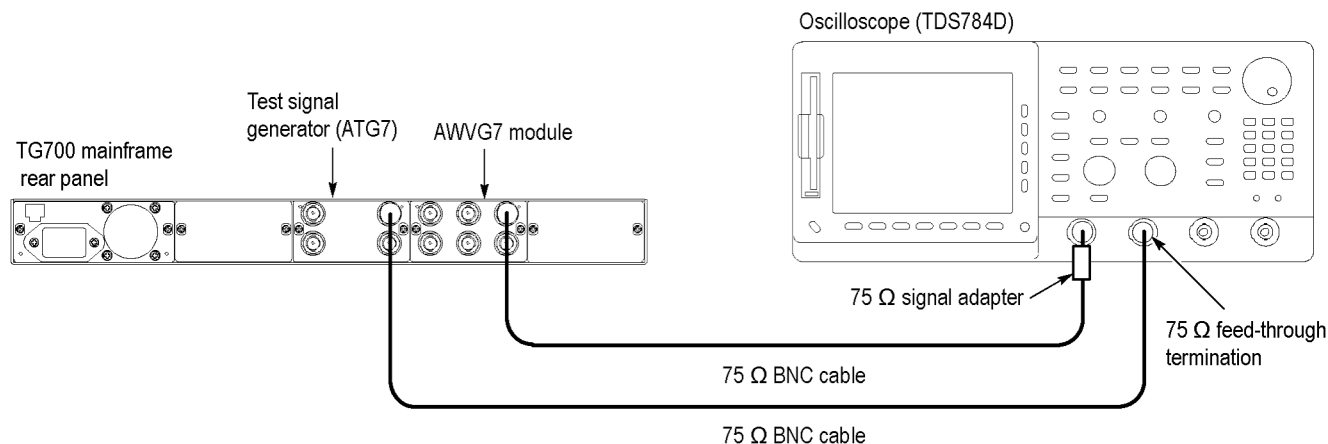

Figure 23: Equipment connection for verifying the field time distortion

3. Set the oscilloscope settings as follows:

Control	Setting
Vertical scale	CH 1: 5 mV/div, CH 2: 1.00 V/div
Vertical offset	700 mV
Horizontal scale	5 ms/div
Horizontal delay time	5.0 μ s/div
Delayed runs time	343.0 μ s (Delayed Only)
Trigger position	50%
Trigger source	CH 2
Trigger type	Edge
Acquire menu	Average 64
CH 2 waveform	OFF
Courser	V Bars
Measure	CH 1 Mean

4. Set the test signal generator (ATG7 module) settings as follows:

Control	Setting
Output selection	BLACK 1

Control	Setting
Signal format	NTSC
Test signal	Field Reference

5. Select the 100% Flat Field signal as follows:
 - a. Press the **MODULE** button to display the AWVG7 main menu.
 - b. Press the **FORMAT** button to select **1080 59i GBR**, and then press **ENTER**.
 - c. Press the **FLAT FIELD** button to select **100% Flat Field**.
6. Place one of the vertical cursor on the portion after 4 μ s of the rising edge of the line bar signal, and place the other vertical cursor on the portion before 4 ms of the falling edge of the line bar signal.
7. On the oscilloscope, select Gate:ON (Gate with V Bar Coursers) from Measure menu.
8. Read the C1 Mean value, and then note this value as V1.
9. Change the Delayed Runs Time value to 8.262 ms, and repeat step 6.
10. Read the C1 Mean value, and then note this value as V2.
11. Verify that the V1 and V2 values meet the following relationships:
$$(V1-V2) / V2 \leq 0.5\%$$
12. Move the BNC cable from the upper CH 1 connector to the upper CH 2 connector on the AWVG7 Generator module and repeat steps 6 through 11.
13. Move the BNC cable from the upper CH 2 connector to the upper CH 3 connector on the AWVG7 Generator module and repeat steps 6 through 11.

Line Time Distortion.

This test verifies the line time distortion of the 100% Flat Field signal from the CH 1, CH 2, and CH 3 outputs. The following equipment is required for the test:

- Oscilloscope
- Test signal generator
- 75 Ω signal adapters
- 75 Ω feed-through termination
- Two 75 Ω BNC cables

Perform the following procedure to verify the line time distortion of the 100% Flat Field signal.

Use the equipment connection from the previous test.

1. Move the BNC cable from the upper CH 3 connector to the upper CH 1 connector on the AWVG7 Generator module.
2. Set the oscilloscope settings as follows:

Control	Setting
Vertical scale	CH 1: 5 mV/div, CH 2: 1.00 V/div
Vertical offset	700 mV
Horizontal scale	20 μ s/div
Horizontal delay time	2.0 μ s/div
Delayed runs time	165.0 μ s (Delayed Only)
Trigger position	50%
Record length	1000
Trigger source	CH 2
Trigger type	Edge
Acquire menu	Average 64
CH 2 waveform	OFF
Courser	V Bars
Measure	CH 1 MAX, CH 1 MIN

3. Set the test signal generator (ATG7 module) settings as follows:

Control	Setting
Output selection	BLACK 1
Signal format	NTSC

Control	Setting
Test signal	Field Reference

4. Select the 100% Flat Field signal as follows:
 - a. Press the **MODULE** button to display the AWVG7 main menu.
 - b. Press the **FORMAT** button to select **1080 59i GBR**, and then press **ENTER**.
 - c. Press the **FLAT FIELD** button to select **100% Flat Field**.
5. Place one of the vertical cursors on the portion after 1 μ s of the rising edge of the line bar signal, and place the other vertical cursor on the portion before 1 ms of the falling edge of the line bar signal.
6. On the oscilloscope, select Gate:ON (Gate with V Bar Cursors) from the Measure menu.
7. Read the **C1 MAX** value and **C1 MIN** value, and then verify that the differences between these values are within 3 mV.
8. Move the BNC cable from the upper CH 1 connector to the upper CH 2 connector on the AWVG7 Generator module and repeat step 7.
9. Move the BNC cable from the upper CH 2 connector to the upper CH 3 connector on the AWVG7 Generator module and repeat step 7.

Color Bars Signal Check. This test verifies that the 75% color bars signal is normally output from all of the channels. The following equipment is required for the test:

- Color picture monitor
- Three 75 Ω BNC cables
- Three 75 Ω coaxial termination

Perform the following procedure to verify that the 75% color bars signal is normally output from all of the channels:

1. Use the 75 Ω BNC cable to connect the upper CH 1 connector on the AWVG7 Generator module to the Y/G IN connector on the color picture monitor as shown in the following figure.
2. Use the 75 Ω BNC cable to connect the upper CH 2 connector on the AWVG7 Generator module to the P_B/B IN connector on the color picture monitor as shown in the following figure.
3. Use the 75 Ω BNC cable to connect the upper CH 3 connector on the AWVG7 Generator module to the P_R/R IN connector on the color picture monitor as shown in the following figure.
4. Use the 75 Ω coaxial terminations to terminate the Y/G OUT, P_B/B OUT, and P_R/R OUT connectors on the color picture monitor.

5. Set the display setting of the color picture monitor to the GBR mode.
6. Select the 75% Color Bars signal as follows:
 - a. Press the **MODULE** button to display the AWVG7 main menu.
 - b. Press the **FORMAT** button to select **1080 59i GBR**, and then press **ENTER**.
 - c. Press the **COLOR BAR** button to select **75% Color Bars**.

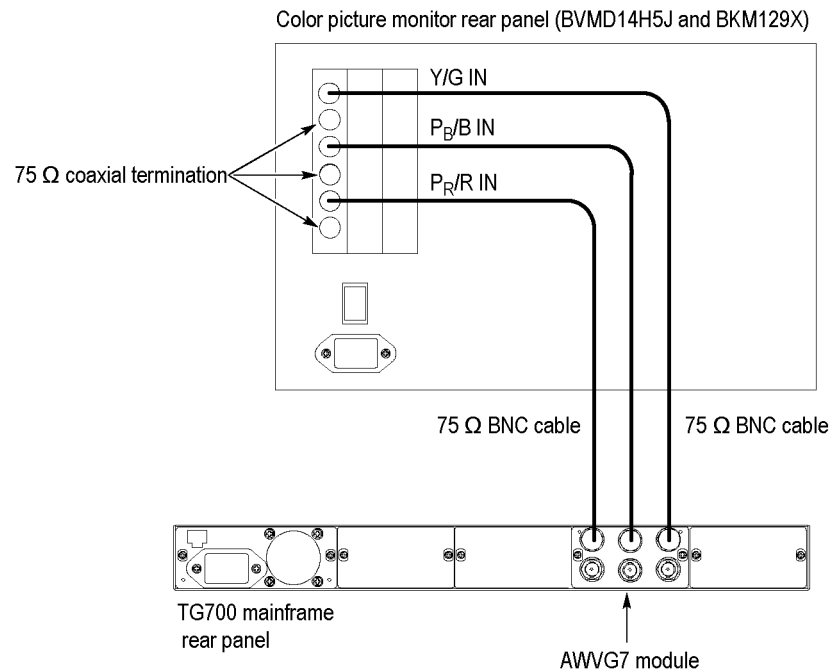

Figure 24: Equipment connection for checking the color bars signal

7. Select the Sync ON All Channels mode as follows:
 - a. Press the up (▲) or down (▼) arrow button to select **VIDEO**, and then press **ENTER** button to access the VIDEO submenu.
 - b. Press the left (◀) or right (▶) arrow button to select **Sync ON All Channels**, and then press **ENTER**.
8. Verify that the color bars signal is displayed normally.
9. Move the BNC cable from the upper CH 1 connector to the lower CH 1 connector, from the upper CH 2 connector to the lower CH 2 connector, and from upper CH 3 connector to lower CH 3 connector on the AWVG7 Generator module and repeat step 8.

This completes the AWVG7 module performance verification procedure. If you require further assistance, contact your nearest Tektronix Service Center.

BG7 Module Performance Verification

The following procedures verify the functionality of the BG7 Black Generator module.

Required Equipment The following table lists the required equipment for the following procedure.

Table 71: Required equipment for BG7 performance verification

Item	No.	Minimum requirement	Recommended equipment
Oscilloscope	1	Bandwidth: 200 MHz or higher	Tektronix TDS540D
Video measurement set	1		Tektronix VM700T Option 01/11
75 Ω BNC cable	1	Length: 42 inches	Tektronix part number 012-0074-00
75 Ω feed-through terminator	1		Tektronix part number 011-0103-02
75 Ω coaxial terminator	1		Tektronix part number 011-0102-01

Test Record Photocopy this table and use it to record the performance test results.

Table 72: BG7 test record

Serial Number	Cal Date	Temperature	Humidity		
Step	Function Tested	Minimum	Cal Data	Maximum	
Black Output (NTSC)					
1.	Blanking Level	BLACK 1	-50 mV	mV	+50 mV
		BLACK 2	-50 mV	mV	+50 mV
		BLACK 3	-50 mV	mV	+50 mV
		BLACK 4	-50 mV	mV	+50 mV
2.	Burst Amplitude	BLACK 1 (Peak to Peak Value)	280.0 mV	mV	291.4 mV
		BLACK 2 (Peak to Peak Value)	280.0 mV	mV	291.4 mV
		BLACK 3 (Peak to Peak Value)	280.0 mV	mV	291.4 mV
		BLACK 4 (Peak to Peak Value)	280.0 mV	mV	291.4 mV
3.	Sync Amplitude	BLACK 1	280.0 mV	mV	291.4 mV
		BLACK 2	280.0 mV	mV	291.4 mV
		BLACK 3	280.0 mV	mV	291.4 mV
		BLACK 4	280.0 mV	mV	291.4 mV
Tri-Level Sync Output					

Table 72: BG7 test record (cont.)

Step	Function Tested		Minimum	Cal Data	Maximum
4.	Blanking Level	BLACK 1	-50 mV	mV	+50 mV
		BLACK 2	-50 mV	mV	+50 mV
		BLACK 3	-50 mV	mV	+50 mV
		BLACK 4	-50 m	mV	+50 mV
5.	Sync Amplitude plus	BLACK 1	294.0 mV	mV	306.0 mV
		BLACK 2	294.0 mV	mV	306.0 mV
		BLACK 3	294.0 mV	mV	306.0 mV
		BLACK 4	294.0 mV	mV	306.0 mV
6.	Sync Amplitude minus	BLACK 1	294.0 mV	mV	306.0 mV
		BLACK 2	294.0 mV	mV	306.0 mV
		BLACK 3	294.0 mV	mV	306.0 mV
		BLACK 4	294.0 mV	mV	306.0 mV
Option CB					
7.	Luminance Gain (Measured on PAL 75% Color Bars Over Red signal)	BLACK 3	693.0 mV	mV	707.0 mV
		BLACK 4	693.0 mV	mV	707.0 mV
8.	Chrominance Gain (Measured on PAL 75% Color Bars Over Red signal)	BLACK 3	650.6 mV	mV	677.0 mV
		BLACK 4	650.6 mV	mV	677.0 mV

Procedures

The following procedure determines if the BG7 Black Generator module is operating correctly.

Be sure you have performed the performance verification preparation before proceeding. (See page 35, *Performance Verification*.)



WARNING. *Dangerous electric shock hazards exist inside the TG700 mainframe. Only qualified service personnel should perform these procedures.*

Trilevel Sync Outputs. This test verifies the blanking level and sync amplitude of trilevel sync signals. The following equipment is required for the test:

- Oscilloscope
- 75 Ω BNC cable
- 75 Ω feed-through terminator

Perform the following procedure to verify that the blanking level and sync amplitude of trilevel sync signals.

1. Use the 75 Ω BNC cable and the 75 Ω feed-through terminator to connect the BLACK 1 connector on the BG7 Generator module to the oscilloscope CH1 input as shown in the following figure.

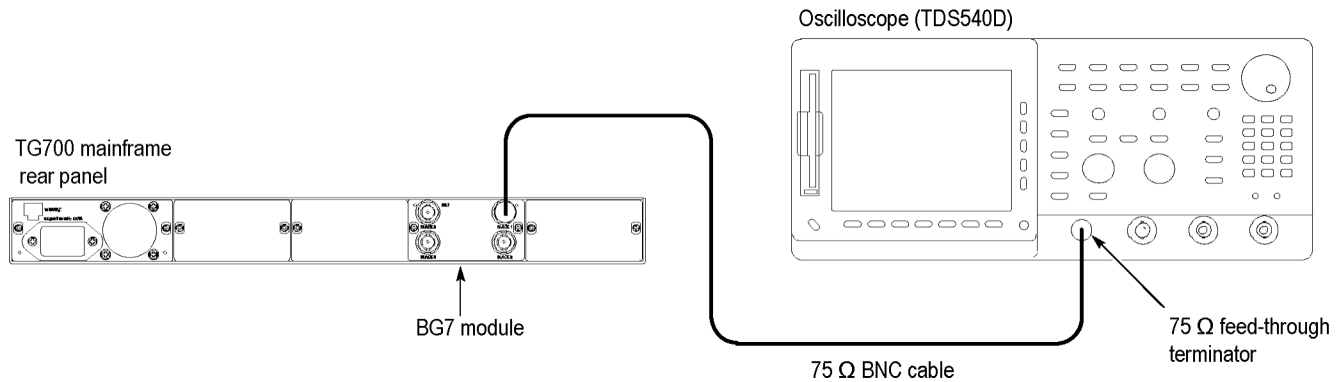

Figure 25: Equipment connection for verifying the trilevel sync outputs

2. Recall the Factory Default preset as follows:
 - a. Press the **MODULE** button to display the TG700 main menu.
 - b. Press the up (**▲**) or down (**▼**) arrow button to select **RECALL**.
 - c. Press the left (**◀**) or right (**▶**) arrow button to select **Factory Default**.
 - d. Press **ENTER** to recall the factory default settings.
3. Select the **1080 59.94i** HD sync signal for BLACK 1 to BLACK 4 as follows:
 - a. Press the **MODULE** button to display the BG7 main menu.
 - b. Press the left (**◀**) or right (**▶**) arrow button to select **BLACK 1**, and then press **ENTER**.
 - c. Press the left (**◀**) or right (**▶**) arrow button to select **HD SYNC**, and then press **ENTER**.
 - d. Press the left (**◀**) or right (**▶**) arrow button to select **1080 59.94i**, and then press **ENTER**.
 - e. Press the **CANCEL** button twice to return the module main menu.
 - f. Repeat parts b through dof this step to select the 1080 59.94i HD sync signal for BLACK 2 to BLACK 4.
4. Set the oscilloscope settings as follows:

Control	Setting
Vertical	50 mV/div
Vertical offset	0 V
Horizontal	500 ns/div

Control	Setting
Horizontal position	Center
Trig position	50%
Trig slope	Rising Edge
Acquire menu	Average 32

5. Verify that the blanking level is within the range of +50 mV to –50 mV.
6. Change the oscilloscope vertical scale to 10 mV/div.
7. Align the blanking level with the center graticule line on the oscilloscope.
8. Change the oscilloscope vertical offset to 300 mV.
9. Verify that the high level of the signal (sync amplitude plus) is within the range of +0.6 div to –0.6 div to the center graticule (except for ringing of the rising edge).
10. Change the oscilloscope vertical offset to –300 mV.
11. Verify that the low level of the signal (sync amplitude minus) is within the range of +0.6 div to –0.6 div to the center graticule (except for ringing of the falling edge).
12. Change the BNC cable connection from BLACK 1 connector to the BLACK 2 connector on the BG7 Generator module and repeat steps 4 through 10.
13. Change the BNC cable connection from BLACK 2 connector to the BLACK 3 connector on the BG7 Generator module and repeat steps 4 through 10.
14. Change the BNC cable connection from BLACK 3 connector to the BLACK 4 connector on the BG7 Generator module and repeat steps 4 through 10.

Black Burst Outputs. This test verifies the blanking level, burst amplitude, and sync amplitude of black burst signals. The following equipment is required for the test:

- Oscilloscope
- Video measurement set
- 75 Ω feed-through terminator
- 75 Ω coaxial terminator

Perform the following procedure to verify that the blanking level, burst amplitude, and sync amplitude of black burst signals.

Use the equipment connection and controls from the previous test.

1. Change the BNC cable connection from BLACK 4 connector to the BLACK 1 connector on the BG7 Generator module.
2. Select the **NTSC Black Burst** signal for BLACK 1 to BLACK 4 as follows:
 - a. Press the **MODULE** button to display the module main menu.
 - b. Press the left (◀) or right (▶) arrow button to select **BLACK 1**, and then press **ENTER**.
 - c. Press the left (◀) or right (▶) arrow button to select **NTSC**, and then press **ENTER**.
 - d. Press the left (◀) or right (▶) arrow button to select **Black Burst**, and then press **ENTER**.
 - e. Press the **CANCEL** button twice to return the module main menu.
 - f. Repeat parts b to d of this step to select the NTSC black burst signal for BLACK 2 to BLACK 4.
3. Set the oscilloscope settings as follows:

Control	Setting
Vertical	50 mV/div
Vertical offset	0 V
Horizontal	1 μ s/div
Horizontal position	Center
Trig position	10%
Acquire menu	Average 32
Measure menu	Mean
Trig type	Video
Trig standard	NTSC
Trig source	CH1
Trig polarity	Negative
Trig filed	Odd Field
Trig line	2
Trig mode	MONO (2 Field)

4. Verify that the blanking level is within the range of +50 mV to –50 mV.
5. Change the BNC cable connection from BLACK 1 connector to the BLACK 2 connector on the BG7 Generator module and repeat step 4.
6. Change the BNC cable connection from BLACK 2 connector to the BLACK 3 connector on the BG7 Generator module and repeat step 4.
7. Change the BNC cable connection from BLACK 3 connector to the BLACK 4 connector on the BG7 Generator module and repeat step 4.

8. Change the BNC cable connection from BLACK 4 connector to the BLACK 1 connector on the BG7 Generator module.
9. Disconnect the BNC cable from the 75 Ω feed-through terminator on the oscilloscope input, and then connect the BNC cable to the CHAN A connector on the video measurement set as shown in the following figure.
10. Use the 75 Ω coaxial terminator to terminate the other loop through to the CHAN A connector on the video measurement set.
11. Press the **Measure** button on the video measurement set to open the Measure mode display.

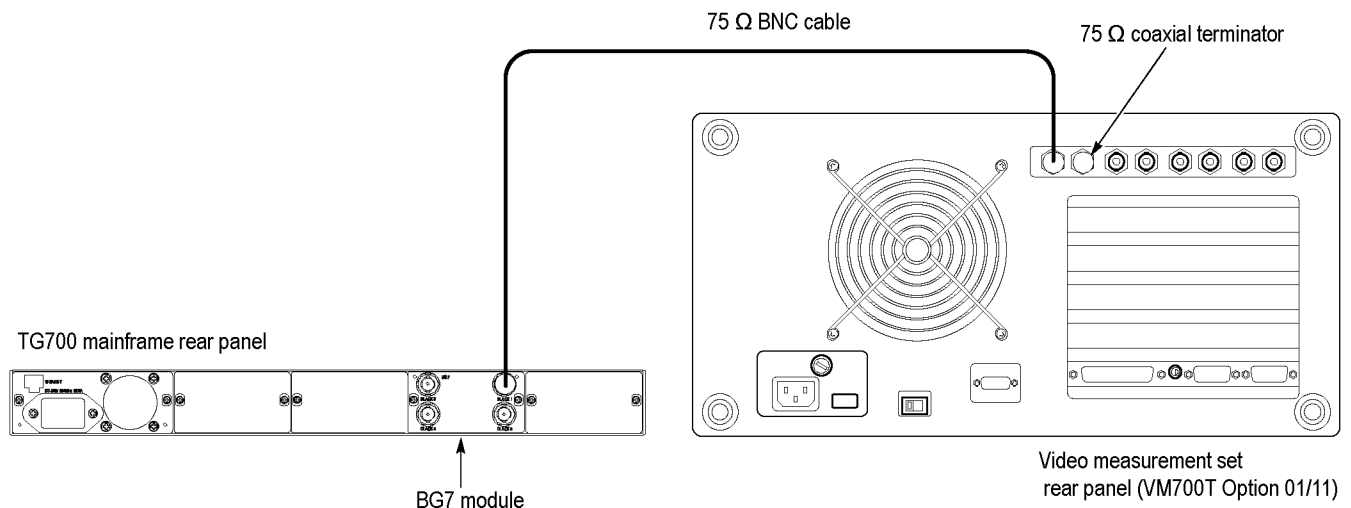

Figure 26: Equipment connection for verifying burst and sync amplitude

12. Touch the **Mode** soft key to set the instrument to Analog mode, and then touch the **H_Timing** soft key.
13. Press the **Menu** button to display the H_Timing main menu.
14. Touch the **Average** soft key and rotate the front-panel knob to set the value to 32.
15. Press the **Select Line** button and rotate the front-panel knob to set the measurement line to 100 (Field=1 Line=100).
16. Verify that the burst and sync amplitude are within the range of 39.2 IRE to 40.8 IRE.
17. Change the BNC cable connection from BLACK 1 connector to the BLACK 2 connector on the BG7 Generator module and repeat step 16.
18. Change the BNC cable connection from BLACK 2 connector to the BLACK 3 connector on the BG7 Generator module and repeat step 16.
19. Change the BNC cable connection from BLACK 3 connector to the BLACK 4 connector on the BG7 Generator module and repeat step 16.

Luminance and Chrominance Gain (Option CB Only). This test verifies the luminance and chrominance gain of the color bars signal.

1. Change the BNC cable connection from BLACK 4 connector to the BLACK 3 connector on the BG7 Generator module.
2. Select the **75% Color Bars Over Red** signal for BLACK 3 and BLACK 4 as follows:
 - a. Press the **MODULE** button to display the BG7 main menu.
 - b. Press the left (◀) or right (▶) arrow button to select **BLACK 3**, and then press **ENTER**.
 - c. Press the left (◀) or right (▶) arrow button to select **PAL**, and then press **ENTER**.
 - d. Press the left (◀) or right (▶) arrow button to select **75% Color Bars Over Red**, and then press **ENTER**.
 - e. Press the **CANCEL** button twice to return the module main menu.
 - f. Repeat parts b through e of this step to select the 75% Color Bars Over Red signal for BLACK 4.
3. Press the **Measure** button on the video measurement set to open the Measure mode display.
4. Touch the **Video Standard** soft key to change the acceptable video standard for PAL.
5. In the Measure mode display, touch the **Color Bar** soft key to open the Color Bar measurement display.
6. Press the **Menu** button to display the Color Bar main menu.
7. Touch the **Average** soft key and rotate the front-panel knob to set the value to 256.
8. Press the **Select Line** button and rotate the front-panel knob to set the measurement line to 100 (Field=1 Line=100).
9. Verify that the luminance gain (level) is within the range of 693.0 mV to 707.0 mV.
10. Verify that the chrominance gain (level) is within the range of 650.6 mV to 677.0 mV. Note that the chrominance gain is measured by Red.
11. Change the BNC cable connection from BLACK 3 connector to the BLACK 4 connector on the BG7 Generator module and repeat steps 8 and 9.

This completes the BG7 module performance verification procedure. If you require further assistance, contact your nearest Tektronix Service Center.

DVG7 Module Performance Verification

The following procedures verify the functionality of the DVG7 Digital Video Generator module.

Required Equipment The following table lists the required equipment for the following procedure.

Table 73: Required equipment for DVG7 performance verification

Item	No.	Minimum requirement	Recommended equipment
Video measurement set	1		Tektronix VM700T Option 01/11/1S
75 Ω BNC cable	1	Length: 42 inches	Tektronix part number 012-0074-00
75 Ω coaxial terminator	1		Tektronix part number 011-0102-01

Test Record Photocopy this table and use it to record the performance test results.

Table 74: DVG7 test record

Serial Number	Cal Date		Temperature	Humidity	
Step	Function Tested		Minimum	Cal Data	Maximum
1.	Serial Output Amplitude	SIGNAL 1	720 mV	mV	880 mV
		SIGNAL 2	720 mV	mV	880 mV
2.	Serial Output Rise Time (20% to 80% amplitude points)	SIGNAL 1	0.40 ns	ns	1.50 ns
		SIGNAL 2	0.40 ns	ns	1.50 ns
3.	Serial Output Fall Time (20% to 80% amplitude points)	SIGNAL 1	0.40 ns	ns	1.50 ns
		SIGNAL 2	0.40 ns	ns	1.50 ns
Option BK					
4.	Serial Output Amplitude	BLACK 1	720 mV	mV	880 mV
		BLACK 2	720 mV	mV	880 mV
5.	Serial Output Rise Time (20% to 80% amplitude points)	BLACK 1	0.40 ns	ns	1.50 ns
		BLACK 2	0.40 ns	ns	1.50 ns
6.	Serial Output Fall Time (20% to 80% amplitude points)	BLACK 1	0.40 ns	ns	1.50 ns
		BLACK 2	0.40 ns	ns	1.50 ns

Procedures The following procedure determines if the BG7 Black Generator module is operating correctly.

Be sure you have performed the performance verification preparation before proceeding. (See page 35, *Performance Verification*.)



WARNING. *Dangerous electric shock hazards exist inside the TG700 mainframe. Only qualified service personnel should perform these procedures.*

Serial Digital Outputs. This test verifies that serial digital signals are output correctly from the SIGNAL 1 and SIGNAL 2 connectors. The following equipment is required for the test:

- Video measurement set
- 75 Ω BNC cable
- 75 Ω coaxial terminator

Perform the following procedure to verify that serial digital signals are output correctly from the SIGNAL 1 and SIGNAL 2 connectors.

1. Use the 75 Ω BNC cable to connect SIGNAL 1 connector on the DVG7 Generator module to the **SDI Ch.A** connector on the video measurement set rear panel as shown in the following figure.
2. Use the 75 Ω coaxial terminator to terminate the other loop through to the **SDI Ch.A** connector on the video measurement set rear panel.

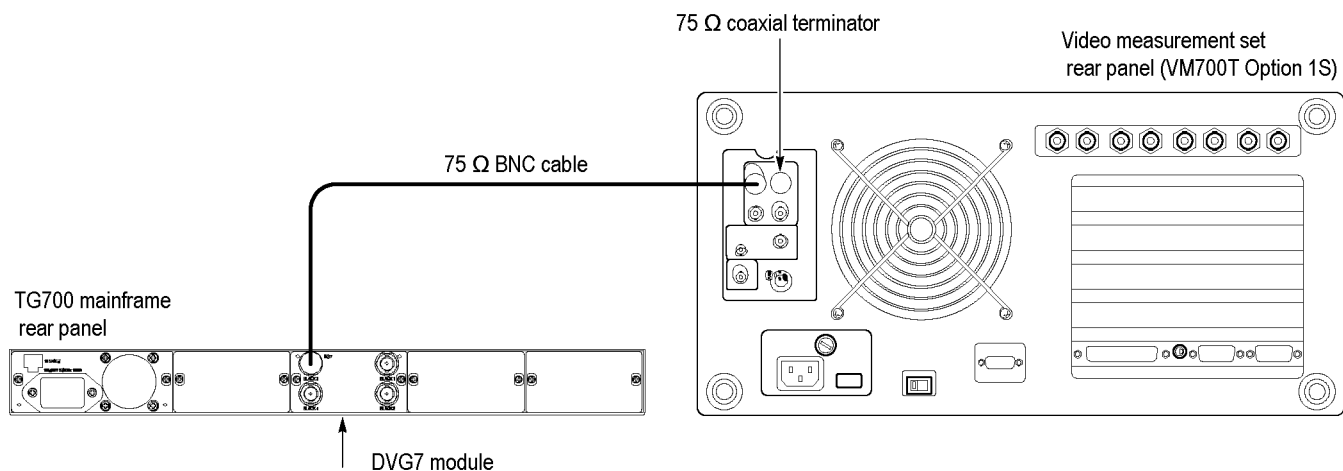

Figure 27: Equipment connection for verifying the serial digital outputs

3. Recall the Factory Default preset as follows:
 - a. Press the **MODULE** button to display the TG700 main menu.
 - b. Press the up (\blacktriangle) or down (\blacktriangledown) arrow button to select **RECALL**.
 - c. Press the left (\blacktriangleleft) or right (\blacktriangleright) arrow button to select **Factory Default**.

- d. Press **ENTER** to recall the factory default settings.
4. Select the **75% Color Bars** signal as follows:
 - a. Press the **MODULE** button to display the DVG7 main menu.
 - b. Press the **COLOR BAR** test signal button until the **75% Color Bars** signal is selected.
 - c. Press the **CANCEL** button to return to the DVG7 main menu.
5. Turn on the circle overlay as follows:
 - a. Press the up (**▲**) or down (**▼**) arrow button to select **OVERLAY**, and then press **ENTER**.
 - b. Press the left (**◀**) or right (**▶**) arrow button to select **Circle**, and then press **ENTER** to access the CIRCLE OVERLAY submenu.
 - c. Press the left (**◀**) or right (**▶**) arrow button to select **Enable**, and then press **ENTER**.
6. Turn on the embedded audio for Group 1 as follows:
 - a. Press the **CANCEL** button to return the module main menu.
 - b. Press the up (**▲**) or down (**▼**) arrow button to select **AUDIO (EMBEDDED)**.
 - c. Press the left (**◀**) or right (**▶**) arrow button to select **Group 1**, and then press **ENTER** to access the AUDIO GROUP submenu.
 - d. Press the left (**◀**) or right (**▶**) arrow button to select **Enable**, and then press **ENTER**.
 - e. Press the **CANCEL** button to return the module main menu.
7. Press the **Measure** button on the video measurement set to open the Measure mode display.
8. Touch the **SDI** soft key to set the measurement set to Digital mode.
9. In the Measure mode display, touch the **SDI Format Monitor** application.
10. Verify that no error messages appear on the SDI Format Monitor display.
11. Press the **Picture** button to set the video measurement set to **SDI Picture** application.
12. Verify that the correct color bar and overlay circle are displayed on the SDI Picture display.
13. Press the **Measure** button on the video measurement set to open the Measure mode display.
14. In the Measure mode display, touch the **SDI Audio Format Analyzer** application.

15. Verify that no CRC error appears on the SDI Audio Format Analyzer display.
16. Move the BNC cable from the SIGNAL 1 connector to the SIGNAL 2 connector on the DVG7 Generator module.
17. Press the **Measure** button on the video measurement set to open the Measure mode display.
18. Repeat steps 9 through 15.

Serial Digital Black Outputs (Option BK Only). This test verifies that serial digital black signals are output correctly from the BLACK1 and BLACK 2 connectors.

19. Move the BNC cable from the SIGNAL 2 connector to the BLACK 1 connector on the DVG7 Generator module.
20. Select the **40% Flat Field** signal as follows:
 - a. Press the **CANCEL** button to return to the module main menu.
 - b. Press the up (▲) or down (▼) arrow button to select **BLACK (OPTION)**.
 - c. Press **ENTER** to access the BLACK submenu.
 - d. Press the up (▲) or down (▼) arrow button to select **SIGNAL**.
 - e. Press the left (◀) or right (▶) arrow button to select **40% Flat Field** and press **ENTER**.
21. Turn on the embedded audio for Group 1 as follows:
 - a. Press the **CANCEL** button to return the BLACK submenu.
 - b. Press the up (▲) or down (▼) arrow button to select **AUDIO (EMBEDDED)**.
 - c. Press **ENTER** to access the AUDIO GROUP submenu for Group 1.
 - d. Press the left (◀) or right (▶) arrow button to select **Group 1**, and then press **ENTER** to access the AUDIO GROUP submenu.
 - e. Press the left (◀) or right (▶) arrow button to select **Enable**, and then press **ENTER**.
 - f. Press the **CANCEL** button to return the BLACK submenu.
22. Press the **Measure** button on the video measurement set to open the Measure mode display.
23. Repeat steps 9 through 15.
24. Change the BNC cable connection from BLACK 1 connector to the BLACK 2 connector on the DVG7 Generator module.
25. Press the **Measure** button on the video measurement set to open the Measure mode display.
26. Repeat steps 9 through 15.

Eye Pattern Check. This test verifies the signal level and rise/fall times of the SIGNAL 1 and SIGNAL 2 outputs. The following equipment is required for the test:

- Video measurement set
- 75 Ω BNC cable
- 75 Ω coaxial terminator

Perform the following procedure to verify the signal level and rise/fall times of the SIGNAL 1 and SIGNAL 2 outputs.

Use the equipment connection and controls from the previous test.

1. Press the **Measure** button on the video measurement set to open the Measure mode display.
2. In the Measure mode display, touch the **SDI Eye Diagram** application to open the Eye Diagram display.
3. In the Eye Diagram display, touch the **Average** soft key to set the value for Eye Persistence to **Infinity**.
4. In the Eye Diagram display, touch the **Measure** soft key to open the Measure submenu.
5. In the Measure submenu, touch the following soft keys to toggle each measurement display on: **Eye Amplitude**, **Rise\Fall Times**, and **Rise\Fall Adjusted**.
6. Verify that the eye amplitude and rise and fall times values are as follows:
Eye amplitude: 720 mV to 880 mV
Rise and fall time: 400 ps to 1500 ps
7. Change the BNC cable connection from the SIGNAL 1 connector to the SIGNAL 2 connector and change the 75 Ω terminator from the SIGNAL 2 connector to the SIGNAL 1 connector on the DVG7 Generator module.
8. Repeat step 6.

BLACK Output Eye Pattern Check (Option BK Only). This test verifies the signal level and rise/fall times of the BLACK 1 and BLACK 2 outputs.

9. Change the BNC cable connection from the SIGNAL 2 connector to the BLACK 1 connector on the DVG7 Generator module.
10. Repeat step 6.
11. Change the BNC cable connection from the BLACK 1 connector to the BLACK 2 connector on the DVG7 Generator module.
12. Repeat step 6.

This completes the DVG7 module performance verification procedure. If you require further assistance, contact your nearest Tektronix Service Center.

GPS7 Module Performance Verification

The following procedures verify the functionality of the GPS7 GPS Synchronization and Timecode module.

Required Equipment The following table lists the required equipment for the following procedure.

Table 75: Required equipment for GPS7 performance verification

Item	No.	Minimum requirements	Recommended equipment
GPS antenna feed with good signal level	1	Less than 5 dB attenuation since last amplifier	Trimble Bullet III, 5v, 35 dB gain, antenna with F-connector, or equivalent Cable (use only if you do not have a GPS feed): up to 200 ft Belden 1694A, or equivalent, with F connector on one end and a BNC on the other
SDI video signal source	1		DVG7 or HDVG7 module in either a reference instrument or the mainframe under test, or can be an external signal
6, 10, and 20 dB antenna pads	variable If antenna has no additional amps, one 6 dB and one 10 dB should be adequate. For a fully buffered system, 30 or 40 dB total is probably needed.	Use several pads that allow similar ranges	6 dB, Mini-circuits HAT-6-75 10 dB, Mini-circuits HAT-10-75 20 dB, Mini-circuits HAT-20-75
Waveform monitor	1		Tektronix WFM7120 with Option CPS
Second reference system	1		Tektronix TG700 with a GPS7 module
Oscilloscope	1		Tektronix TDS3054B or equivalent with 100 MHz or greater bandwidth to measure 10 MHz sine amplitude and video rise and fall times
Voltmeter	1		Fluke
LTC/GPIO breakout adapter cable	1		Tektronix part number 012-1717-00
600 Ω LTC load with meter access	1		Create this item by soldering a 600 Ω resistor to pins 2 and 3 of a female XLR

Table 75: Required equipment for GPS7 performance verification (cont.)

Item	No.	Minimum requirements	Recommended equipment
Antenna splitter	1	Use to drive one signal into two GPS7 inputs	Any 2:1 splitter with appropriate connector adapters or GPS Source S12S with (3) SMA to BNC adapters, Tyco part number 1058083-1 or ZFDC-10-5-S with 3 SMA to BNC adapters, Tyco part number 1058083-1
75 Ω , precision terminator	1		Tektronix part number 011-0102-03
75 Ω feed-through terminator	1		Tektronix part number 011-0055-02
75 Ω coaxial terminator	2		Tektronix part number 011-0163-00
BNC T	2		Tektronix part number 103-0030-00
BNC to Banana Plug adapter	1		Pomona model 1269
75 Ω BNC cable	4	3 ft long	Tektronix part number 012-0074-00
BNC-to-test clip adapter	1	Use to help measure voltage across 600 Ω load resistor for LTC level procedure	

Test Record Photocopy this table and use it to record the performance test results.

Table 76: GPS7 test record

Serial number	Cal date	Temperature			
Step	Function tested	Measured value		Value	Value
		- Min	+Max		
Preparation					
	errors			Pass	Fail
	TG700 diagnostics			Pass	Fail
	GPS7 diagnostics			Pass	Fail
DC antenna output power voltage					
	0 V				
	3.3 V	3.3 V	4 V		
	5 V	5 V	6 V		
Antenna current and fault thresholds					
	Flashing green (open circuit)			Pass	Fail
	Steady green (nominal load)			Pass	Fail
	Voltage with nominal load	4.5 V	5 V		
	Steady red (short circuit)			Pass	Fail
Lock to GPS signal from antenna					
	Signal quality (reference unit)	40	80		
	Difference in signal quality between reference unit and unit under test	≤ 20 units from reference unit value	≥ 20 units from reference unit value		
Black output functional test and frame pulse test					
Black 1	NTSC			Pass	Fail
	1080 60i			Pass	Fail
Black 2	1080 50i			Pass	Fail
	PAL			Pass	Fail
Black 3	PAL			Pass	Fail
	1080 24p			Pass	Fail
Black output bit integrity					

Table 76: GPS7 test record (cont.)

Serial number	Cal date	Temperature				
Step	Function tested	- Min	+Max	Measured value	Value	Value
Black 1	Ramp				Pass	Fail
	Calibration setting (AMPL. DAC number)					
Black 2	Ramp				Pass	Fail
	Calibration setting (AMPL. DAC number)					
Black 3	Ramp				Pass	Fail
	Calibration setting (AMPL. DAC number)					
Black amplitude and offset						
Black 1	0 mV (offset)	- 40 mV	+ 40 mV			
	700 mV					
	Amplitude (difference)	693 mV	707 mV			
Black 2	0 mV (offset)	- 40 mV	+ 40 mV			
	700 mV					
	Amplitude (difference)	693 mV	707 mV			
Black 3	0 mV (offset)	- 40 mV	+ 40 mV			
	700 mV					
	Amplitude (difference)	693 mV	707 mV			
Black output rise and fall time						
Black 1, NTSC	fall time of falling sync edge	120 ns	150 ns			
Black 1, 1080 60i	rising edge in the middle of the tri-level sync	40 ns	60 ns			
Black 2, NTSC	fall time of falling sync edge	120 ns	150 ns			
Black 2, 1080 60i	rising edge in the middle of the tri-level sync	40 ns	60 ns			
Black 2, NTSC	fall time of falling sync edge	120 ns	150 ns			

Table 76: GPS7 test record (cont.)

Serial number	Cal date	Temperature				
Step	Function tested	- Min	+Max	Measured value	Value	Value
Black 2, 1080 60i	rising edge in the middle of the tri-level sync	40 ns	60 ns			
Sine amplitude						
	sine amplitude	1.35 V	1.65 V			
LTC level						
LTC 1	Maximum positive voltage					
	Maximum negative voltage					
	p-p voltage (difference)	4.5 V	5.5 V			
LTC 2	Maximum positive voltage					
	Maximum negative voltage					
	p-p voltage (difference)	4.5 V	5.5 V			
LTC 3	Maximum positive voltage					
	Maximum negative voltage					
	p-p voltage (difference)	4.5 V	5.5 V			
LTC 4	Maximum positive voltage					
	Maximum negative voltage					
	p-p voltage (difference)	4.5 V	5.5 V			
GPI output functional test						
	GPI 1	4.5 V	5.5 V			
	GPI 1 (antenna disconnected)		< 0.5 V			
	GPI 2	4.5 V	5.5 V			
	GPI 2 (antenna disconnected)		< 0.5 V			

Table 76: GPS7 test record (cont.)

Serial number	Cal date	Temperature					
		Step	Function tested	- Min	+Max	Measured value	Value
GPI input functional test							
	Program time					Pass	Fail
Frequency accuracy when locked to GPS							
	Vector phase change	- 38 °	+ 38 °				
Frame timing accuracy							
	Timing	- 0.185 μ s	+ 0.185 μ s				
	Internal frequency	6,000	20,000				
	Gain calibration	100	200				

Procedures



WARNING. *Dangerous electric shock hazards exist inside the TG700 mainframe. Only qualified service personnel should perform these procedures.*

Be sure you have performed the performance verification preparation before proceeding. (See page 35, *Performance Verification Preparation*.)

Performance verification procedures can be performed individually, if needed.

Check the GPS7 module Diagnostics before starting these procedures by performing the following steps:

1. Press the **MODULE** button to navigate to the **GPS7** module.
2. Use the up (▲) or down (▼) arrow button to select **DIAGNOSTICS**.
3. Press the **ENTER** button.
4. Use the left (◀) or right (▶) arrow button to scroll through the diagnostics readings and check for any warnings or errors.
5. Record Pass or Fail in the test record.

Start Up In Factory Mode

Although not all of the following tests need to be performed in Factory Mode, they can be. If you are going to perform all of the procedures, or a particular set of procedures, start up the instrument in factory mode at the start of the first procedure.

Leave the instrument in factory mode until you are finished or the instructions say otherwise.

To start up in factory mode, perform the following procedure:

1. Cycle the mainframe power by unplugging the power cord from the rear of the instrument and then holding the **FRONT PANEL ENABLE** button while plugging the power back into the instrument. Continue to hold the button during start up until **TG700 Start up with factory mode** shows on the display.
2. Restore the factory preset:
 - a. Press the **ENTER** button to select **PRESET RECALL**.
 - b. Press the left (◀) arrow button until **Factory Default** appears.
 - c. Press the **ENTER** button to load the preset.
3. When loading is complete, press the **CANCEL** button to exit the Factory Default menu.

DC antenna output power voltage. Perform the following procedure to check that the DC antenna power output is in the proper voltage range.

1. Connect the BNC-to-Banana-plug adapter to the voltmeter.
2. Connect the BNC T to the adapter.
3. Connect a 75 Ω BNC cable to the other end of the BNC T connector.
4. Connect the other end of the cable to the antenna input on the rear of the module.
5. Measure the voltage and record the value in the test record.
6. Set the antenna voltage to 3.3 V:
 - a. Press the **MODULE** button to navigate to the **GPS7** module.
 - b. Use the up (**▲**) or down (**▼**) arrow button to select **GPS SETUP**.
 - c. Press the **ENTER** button.
 - d. Use the up (**▲**) or down (**▼**) arrow button to select **Antenna Power**.
 - e. Use the left (**◀**) or right (**▶**) arrow button to select **3.3 V**.
 - f. Press the **ENTER** button.
7. Check that the voltmeter shows between 3.3 V and 4 V.
8. Record the result in the test record.
9. Now set the antenna voltage to 5 V:
 - a. Use the left (**◀**) or right (**▶**) arrow button to select **5 V**.
 - b. Press the **ENTER** button.
10. Check that the voltmeter shows between 5 V and 6 V.
11. Press the **CANCEL** button to exit the Antenna Power menu.
12. Record the result in the test record.

Antenna current and fault thresholds. Perform the following procedure to check that the antenna current and fault thresholds are within limits.

1. Connect the BNC-to-Banana-plug adapter to the voltmeter.
2. Connect the BNC T to the adapter.
3. Set the antenna voltage to 5 V if it is not already:
 - a. Press the **MODULE** button to navigate to the **GPS7** module.
 - b. Use the up (**▲**) or down (**▼**) arrow button to select **GPS SETUP**.
 - c. Press the **ENTER** button.
 - d. Use the up (**▲**) or down (**▼**) arrow button to select **Antenna Power**.
 - e. Use the left (**◀**) or right (**▶**) arrow button to select **5 V**.
 - f. Press the **ENTER** button.
4. Connect a 75 Ω BNC cable to the other end of the BNC T connector.
5. Connect the other end of the cable to the antenna input on the rear of the module.
6. Check that the LED located between the DSUB connector and the antenna input on the rear panel of the module is flashing green. This indicates an open circuit.
7. Record Pass or Fail in the test record.
8. Apply a 75 Ω precision terminator to the BNC T connector and check that the voltage is between 4.5 V and 5 V.
9. Record the result in the test record.
10. Check that the LED on the module rear panel is a steady green. This indicates a nominal load.
11. Record the Pass or Fail in the test record.
12. Remove the BNC-to-Banana adapter from the BNC T, and install a second BNC T and a precision terminator on the end of the cable to the antenna input. This will exceed the allowed current on the antenna.
13. Check that the LED on the module rear panel is a steady red. This indicates a short circuit.
14. Record the result in the test record.

Lock to GPS signal from antenna. Perform the following procedure to check that the GPS locks onto the minimum allowable signal. This test requires a reference GPS7 unit.

1. Set the antenna power as needed by the antenna in the test system.
2. Connect an antenna splitter to the GPS input signal feed.
3. Connect one output of the splitter to the GPS antenna input of the reference unit and then power on the unit.
4. Connect the other output of the splitter to the GPS antenna input of the module under test.
5. Check the signal quality on both the module under test and the reference unit:
 - a. Use the up (▲) or down (▼) arrow button to select **STATUS** from the GPS7 module menu.
 - b. Use the left (◀) or right (▶) arrow button to select **Signal Quality**.
 - c. If the signal quality does not already show “Locked”, check that the signal quality changes from *No Signal* to *Low Signal* to *Acquiring satellites* to *Adjusting phase* to *Locked*.

NOTE. *It is okay if some steps are skipped. Depending on the signal level, it may take from a few seconds to several minutes to leave the “No Signal” state.*

6. Add attenuating pads between the antenna and the splitter until the signal quality on the reference unit is in the 40 to 80 range.
7. Record the signal quality of the reference unit in the test record.
8. Check that the signal quality on the module under test is within 20 counts of the reference unit.
9. Record the difference between the reference unit and the unit under test in the test record.
10. Remove the attenuators from the input to the splitter and reconnect the signal from the antenna. If possible, leave the antenna connected during subsequent tests to allow the system to stabilize.

Black output functional test and frame pulse test. Perform the following procedure to check that Black signal output and internal frame pulse signals are functioning properly.

1. Connect an SDI signal, like one from a DVG7 or HDVG7 module, to the SDI input of a WFM7120, and select that input as the active input on the waveform monitor.

2. Connect a cable from the Black 1 output on the module to the external reference input of the WFM7120, and terminate the loop through on the monitor with a 75 Ω terminator.
3. Press the **EXT REF** button on the WFM7120.
4. Set Black 1 to NTSC on the GPS7 module:
 - a. Use the up (**▲**) or down (**▼**) arrow button to **SELECT OUTPUT**.
 - b. Press the **ENTER** button when **Black 1** appears.
 - c. Press the **ENTER** button again when **NTSC** appears.
 - d. Use the left (**◀**) or right (**▶**) arrow button to select **Black Burst**.
 - e. Press the **ENTER** button.
5. Check that the WFM7120 shows NTSC as the reference input.
6. Record the result in the test record.
7. Press the **CANCEL** button to exit the NTSC submenu.
8. Use the left (**◀**) or right (**▶**) arrow button to select **1080 60i** in the Select Format menu.
9. Press the **ENTER** button.
10. Check that the WFM7120 shows a 1080 60i signal on the reference input.
11. Record the result in the test record.
12. Disconnect the Black 1 signal from the WFM7120 and module.
13. Connect the Black 2 output from the module to the Reference input of the WFM7120.
14. Set Black 2 to a 1080i 50 signal on the GPS7 module:
 - a. Press the **CANCEL** button to exit the Black 1 submenu.
 - b. Use the left (**◀**) or right (**▶**) arrow button to select **Black 2**.
 - c. Press the **ENTER** button.
 - d. Use the left (**◀**) or right (**▶**) arrow button to select **1080 50i**.
 - e. Press the **ENTER** button.
15. Check that the WFM7120 shows a 1080i 50 signal on the reference input.
16. Record the result in the test record.
17. Use the right (**▶**) arrow button to select **PAL**.
18. Press the **ENTER** button.
19. Use the left (**◀**) arrow button to select **Black Burst**.

20. Press the **ENTER** button.
21. Check that the WFM7120 shows PAL on the reference input.
22. Record the result in the test record.
23. Press the **CANCEL** twice to exit the Select Format submenu.
24. Disconnect the Black 2 signal from the WFM7120 and the module.
25. Connect the Black 3 output from the module to the reference input of the WFM7120.
26. Set Black 3 to a PAL signal on the GPS7 module:
 - a. Use the right (▶) arrow button to select **Black 3**.
 - b. Press the **ENTER** button.
 - c. Use the right (▶) arrow button to select **PAL**.
 - d. Press the **ENTER** button.
 - e. Use the left (◀) or right (▶) arrow button to select **Black Burst**.
 - f. Press the **ENTER** button.
 - g. Check that the WFM7120 shows PAL on the reference input.
 - h. Press the **CANCEL** button to exit the PAL submenu.
27. Record the result in the test record.
28. Use the left (◀) or right (▶) arrow button to select **1080 24p**.
29. Press the **ENTER** button.
30. Check that the WFM7120 shows 1080p 24 on the reference input.
31. Record the result in the test record.
32. Press the **CANCEL** button to exit the **Select Format** menu.
33. Disconnect the cable from the Black 3 input on the module.

Black output bit integrity. Perform the following test to insure that all the bits in the black generators are working correctly. This test should be performed in factory mode. (See page 152.)

1. Connect a cable from the Black 1 output on the module to the CMPST A input on the WFM7120, and terminate the loop through with a 75 Ω terminator.
2. Activate the WFM7120 composite input and external reference by pressing the Input C button and the **EXT REF** button, respectively, on the WFM7120 front panel.
3. Press the **MODULE** button to select **GPS7**.
4. Use the up (**▲**) or down (**▼**) arrow button to select **SELECT OUTPUT**.
5. Use the left (**◀**) or right (**▶**) arrow button, if needed, to select **Black 1**.
6. Press the **ENTER** button.
7. Use the up (**▲**) or down (**▼**) arrow button to select **SELECT CALIBRATION**.
8. Press the **ENTER** button to select **Amplitude Calibration**.

NOTE. Write down the calibration setting (AMPL. DAC number) in case you need to restore it later.

9. Use the right (**▶**) arrow to select the **RampHPF** ramp signal.
10. Look at the three ramps on the WFM7120 display. The larger of the two ramps should each have 16 equal steps.

NOTE. View the waveform display in full screen mode for easiest viewing.

11. Use the Gain function on the WFM7120 to expand the signal to 10X.
12. Now check that the shallowest ramp has 16 equal steps.
13. Record Pass or Fail in the test record.
14. Check that the calibration setting has not changed. If it has, then restore the original value.
15. Press the **CANCEL** button twice to exit the calibration menu.
16. Repeat this procedure for the Black 2 and Black 3 outputs.

Black Amplitude and Offset. Perform this procedure to check that Black signal output amplitude and offset are adjusted to within specification. This test should be performed in factory mode. (See page 152.)

NOTE. *If any channel fails the following tests, then see the Adjust procedure to set the gain/offset.*

1. Connect the BNC-to-Banana-plug adapter to the voltmeter.
2. Connect the BNC T to the adapter.
3. Connect a 75 Ω precision terminator to one end of the BNC T connector.
4. Connect a 75 Ω BNC cable to the other end of the BNC T connector.
5. Connect the other end of the cable to the Black 1 output on the rear of the module.
6. Press the **MODULE** button to select **GPS7**, if it is not already selected.
7. Use the up (**▲**) or down (**▼**) arrow button to select **SELECT OUTPUT**.
8. Use the left (**◀**) or right (**▶**) arrow button, if needed, to select **Black 1**.
9. Press the **ENTER** button.
10. Use the up (**▲**) or down (**▼**) arrow button to select **SELECT CALIBRATION**.
11. Press the **ENTER** button to select **Amplitude Calibration**.

NOTE. *Write down the calibration setting (AMPL. DAC number) in case you need to restore it later.*

12. Check that the calibration mode signal is 0 V on the TG700 display. This value is displayed in parentheses after the AMPL. DAC number.
13. Record the voltmeter reading in the test record. This is the offset value.
14. Use the right (**▶**) arrow to select the 700 mV level.
15. Record the value in the test record.
16. Calculate the difference between the 700 mV and 0 mV signal levels and record this in the test record.
17. Check that the calibration setting has not changed. If it has, then restore the original value.
18. Exit the calibration mode for the Black 1 signal.
19. Repeat the above steps for Black 2 and Black 3 outputs.

Black Output Rise and Fall Time. Perform this procedure to check that the Black output rise and fall time meet specifications.

1. Connect the Black 1 output of the module to the oscilloscope and terminate the input with a 75 Ω feedthrough terminator.

NOTE. *Make sure that the oscilloscope input is set to 1 M Ω mode if you are using the feedthrough terminator.*

2. Press the **MODULE** button to select **GPS7**.
3. Use the up (**▲**) or down (**▼**) arrow buttons to select **SELECT OUTPUT**.
4. Press the **ENTER** button to select **Black 1**.
5. Press the **ENTER** button to select **NTSC**.
6. Press the **ENTER** button again to select **Black Burst**.
7. Use the oscilloscope to measure the 10 % to 90 % fall time of the falling sync edge.
8. Record the result in the test record.
9. Press the **CANCEL** button to exit the NTSC submenu.
10. Use the right (**▶**) arrow to select a **1080 60i** signal format.
11. Press the **ENTER** button.
12. Use the oscilloscope to measure the 10% to 90% rise time of the rising edge in the middle of the trilevel sync.
13. Record the result in the test record.
14. Repeat the above steps for Black 2 and Black 3 outputs.

Sine Amplitude. Perform this procedure to check the sine amplitude.

1. Connect the Black 3 output to the oscilloscope, and terminate the input with a $75\ \Omega$ feed-through terminator.
2. Press the **MODULE** button until **GPS7** appears.
3. Use the up (**▲**) or down (**▼**) arrow buttons to select **SELECT OUTPUT**.
4. Use the left (**◀**) or right (**▶**) arrow button to select **Black 3**.
5. Press the **ENTER** button.
6. Use the left (**◀**) or right (**▶**) arrow button to select **CW 10 MHz**.
7. Press the **ENTER** button.
8. Measure the amplitude of the sine wave on the oscilloscope.
9. Record the result in the test record.

LTC level. Perform this test to check the LTC levels are within limits. This test should be performed in factory mode. (See page 152.)

1. Create an LTC load with voltmeter access by soldering a 600 Ω resistor to pins 2 and 3 of the female XLR connector.
2. Connect the LTC load with voltmeter access to the LTC 1 connector on the LTC/GPIO breakout adapter cable.
3. Connect the LTC/GPIO adapter cable to the DSUB connector on the rear of the module.
4. Connect a BNC-to-test clip adapter to the voltmeter using a BNC-to-Banana adapter and BNC cable.
5. Attach the clips to either side of the 600 Ω resistor.
6. Press the **MODULE** button until **GPS7** appears.
7. Use the up (**▲**) or down (**▼**) arrow buttons to select **SELECT LTC**.
8. Press the **ENTER** button to select **LTC 1**.
9. Use the up (**▲**) or down (**▼**) arrow button to select **CALIBRATION**.
10. Use the left (**◀**) or right (**▶**) arrow button to select **Set maximum positive voltage**.
11. Press the **ENTER** button.
12. Use the up (**▲**) or down (**▼**) arrow button to select **Output Level**.
13. Use the right (**▶**) arrow button to select **5.0 V**.
14. Press the **ENTER** button.
15. Record the voltage result in the test record.
16. Use the down (**▼**) arrow button to select **CALIBRATION**.
17. Use the left (**◀**) arrow button to select **Set maximum negative voltage**.
18. Press the **ENTER** button.
19. Record the voltage result in the test record.
20. Solve for the difference between the two voltages you recorded to get the p-p voltage.
21. Record the result in the test record.
22. Repeat this procedure for LTC 2, LTC 3, and LTC 4.

GPI output functional test. This procedure checks that the GPI output is functioning properly.

1. Check that the antenna signal is connected to the antenna input of the module and that the instrument shows the signal is locked:
 - a. Press the **MODULE** button until **GPS7** appears.
 - b. Use the up (**▲**) or down (**▼**) arrow button, if needed, to select **STATUS**.
 - c. Check that the top line of the status display shows **Locked**.
2. Connect GPI 1 output to the voltmeter:
 - a. Connect the BNC-to-Banana-plug adapter to the voltmeter.
 - b. Connect the LTC/GPIO breakout adapter cable to the LTC/GPI DSUB on the back of the GPS7 module.
 - c. Connect the GPI 1 connector on the breakout cable to the BNC-to-Banana-plug adapter.
3. Configure GPI 1 output to be asserted on unlock:
 - a. Press the **MODULE** button until **GPS7** appears.
 - b. Use the up (**▲**) or down (**▼**) arrow button to select **SELECT GPIO**.
 - c. Use the left (**◀**) or right (**▶**) arrow button to select **Output 1**.
 - d. Press the **ENTER** button.
 - e. Use the left (**◀**) or right (**▶**) arrow button to select **Loss of lock**.
 - f. Press the **ENTER** button.
4. Check that the voltage on the GPI 1 output measures between 4.5 V and 5.5 V.
5. Record the result in the test record.
6. Disconnect the antenna input. After 15 seconds, check that the GPI 1 output is below 0.5 V.
7. Record the result in the test record.
8. Reconnect the antenna input.
9. Repeat this procedure for the GPI 2 output.

GPI input functional test. This procedure checks that the GPI input is functioning correctly.

1. Configure the GPS7 GPI input to reset the program time:
 - a. Press the **MODULE** button until **GPS7** appears.
 - b. Use the up (▲) or down (▼) arrow button to select **SELECT GPIO**.
 - c. Use the left (◀) or right (▶) arrow button to select **Input 1**.
 - d. Press the **ENTER** button.
 - e. Use the left (◀) or right (▶) arrow button to select **Reset Program Time**.
 - f. Press the **ENTER** button.
 - g. Press the **CANCEL** button to exit the Select GPIO menu.
2. Press the up (▲) arrow to select the **STATUS** display.
3. If needed, use the left (◀) or right (▶) arrow button to display **Program Time**.
4. Write down the program time.
5. Connect the LTC/GPIO breakout adapter cable to the LTC/GPI DSUB on the back of the GPS7 module.
6. Attach a 75 Ω terminator to the GPI input for 2 seconds, and then remove it.
7. Look at the program time now and compare it to the program time you wrote down before. The time on the display should have reset to the default start time of 00:00:00:00 and now be counting again.
8. Record Pass or Fail in the test record.

Frequency accuracy when locked to GPS. This procedure checks that the frequency is accurate when locked to the GPS.

1. Check that the antenna is connected to both a TG700 reference unit with a GPS7 module (or other reference instrument) and the GPS7 module under test.
2. Check that both GPS modules have been on for 20 minutes to allow the ovens to warm up.
3. Check that the signal is locked:
 - a. Press the **MODULE** button until **GPS7** appears.
 - b. Use the up (▲) or down (▼) arrow button, if needed, to select **STATUS**.
 - c. Check that the top line of the status display shows **Locked**.
4. Use the left (◀) or right (▶) arrow button to select **Signal Quality**.
5. Check the value on both units. A value of 30 or above is adequate.
6. Go to the diagnostics page and check that both systems are in **Fine** mode. If they are not, then allow them to warm up and stabilize.
 - a. Use the up (▲) arrow button to select **DIAGNOSTICS**.
 - b. Press the **ENTER** button.
 - c. Press the right (▶) arrow to display **TUNE**.
 - d. Check that **Fine** shows on the right side of the display.
 - e. Press **CANCEL** to exit Diagnostics menu.
7. Set the Black 1 output on both units to output NTSC:
 - a. Use the up (▲) or down (▼) arrow button to select **SELECT OUTPUT**.
 - b. Use the left (◀) or right (▶) arrow button to select **Black 1**.
 - c. Press **ENTER** twice to select **NTSC** and **Black Burst**.

- 8.** Connect Black 1 of the reference unit to the reference input to the WFM7120, and terminate the other reference input on the system under test with a 75 Ω terminator.
- 9.** Connect Black 1 of the system under test to the CMPST A input of the WFM7120, and terminate the loop through with a 75 Ω terminator.
- 10.** Display the composite input on the WFM7120 and select external reference.
- 11.** View the Vector Display in full screen mode.
- 12.** Use the variable gain function to expand the burst to overlap the compass rose graticule.
- 13.** Write down the minimum and maximum vector phase you observe over a 30 second period.
- 14.** Calculate the difference and record the result in the test record.

Frame Timing Accuracy. Perform this procedure to check the accuracy of the frame timing.

This test set up is the same as the previous test.

1. Check that the antenna is connected to both a TG700 reference unit with a GPS7 module (or other reference instrument) and the GPS7 module under test, and that the instruments show the signal is locked:
 - a. Press the **MODULE** button until **GPS7** appears.
 - b. Use the up (**▲**) or down (**▼**) arrow button, if needed, to select **STATUS**.
 - c. Check that the top line of the status display shows **Locked**.
2. Check that both GPS modules have been on for 20 minutes to allow the ovens to warm up.
3. Use the left (**◀**) or right (**▶**) arrow button to select **Signal Quality**.
4. Check the value on both units. A value of 30 or above is adequate.
5. Go to the diagnostics page and check that both systems are in **Fine** mode. If they are not, then allow them to warm up and stabilize.
 - a. Use the up (**▲**) arrow button to select **DIAGNOSTICS**.
 - b. Press the **ENTER** button.
 - c. Press the right arrow to display **TUNE**.
 - d. Check that **Fine** shows on the right side of the display.
 - e. Press **CANCEL** to exit Diagnostics menu.
6. Set the Black 1 output on both units to output NTSC:
 - a. Use the up (**▲**) or down (**▼**) arrow button to select **SELECT OUTPUT**.
 - b. Use the left (**◀**) or right (**▶**) arrow button to select **Black 1**.
 - c. Press **ENTER** twice to select **NTSC** and **Black Burst**.
7. Connect Black 1 of the reference unit to the reference input to the WFM7120, and terminate the other reference input on the system under test with a 75 Ω terminator.
8. Connect Black 1 of the system under test to the CMPST A input of the WFM7120, and terminate the loop through with a 75 Ω terminator.
9. Display the composite input on the WFM7120 and select external reference.
10. View the Timing Display in full screen mode.
11. Record the timing value in the test record.

Internal frequency calibration. Perform the following procedure to set the internal frequency of the mainframe internal oscillator. This adjustment stores the current frequency of the oscillator while it is locked to a GPS or a reference signal, to be used when in **Internal** mode. It can be done without any disruption to operation and is best done in the operating environment of the instrument.

1. Connect the power cord to the TG700 mainframe.
2. Check for error messages as the instrument starts.
3. Connect a GPS signal to the rear of the module.
4. Allow the instrument to warm up for a minimum of 20 minutes.
5. Press the **MODULE** button until **GPS7 : STATUS** appears.
6. Check that the signal status shows **Locked**.
7. Check that signal lock indicator displays **Fine**:
 - a. Press the up (▲) arrow button to select **DIAGNOSTICS**.
 - b. Press the **ENTER** button.
 - c. Press the right (▶) arrow button to select **TUNE**.
 - d. Check that **Fine** is showing on the right side of the LCD display.
8. Press the **MODULE** button until **TG700** appears.
9. Press the up (▲) arrow button to select **UTILITY**.
10. Press the **ENTER** button.
11. Press the up (▲) arrow button to select **CAL OVEN : SELECT**.
12. Press the **ENTER** button to access the **Internal Frequency Calibration** submenu.
13. Press the **ENTER** button to start the calibration.
14. Record the calibration value in the test record.

NOTE. *If the value is outside the test limits, then the Oven is near the edge of the tune range and might need to be replaced.*

15. Press the **ENTER** button to return to the calibration menu.
16. Press the **CANCEL** button to exit the calibration menu.

Gain calibration. Perform the following procedure to characterize the oscillator frequency as a function of voltage. This adjustment needs to be performed in factory mode and is only needed once to characterize the oscillator.



CAUTION. *To avoid signal errors, only perform the Gain Calibration when the instrument is out of service. This calibration temporarily disrupts the frequency of all signals in the box.*

1. Connect a GPS signal to the antenna input on the rear of the module.
2. If the instrument is not already in factory mode, put it in factory mode by performing the following steps:
 - a. Cycle the mainframe power by unplugging the power cord from the rear of the instrument and then holding the **FRONT PANEL ENABLE** button while plugging the power back into the instrument. Continue to hold the button during start up until **TG700 Start up with factory mode** shows on the LCD display.
 - b. Allow the instrument to warm up for a minimum of 20 minutes.
3. Press the **MODULE** button until **GPS7 : STATUS** appears.
4. Check that the signal status shows **Locked**.
5. Check that signal lock indicator displays **Fine**:
 - a. Press the up (**▲**) arrow button to select **DIAGNOSTICS**.
 - b. Press the **ENTER** button.
 - c. Press the right (**▶**) arrow button to select **TUNE**.
 - d. Check that **Fine** is showing on the right side of the LCD display.
6. Press the **MODULE** button until **TG700** appears.
7. Press the up (**▲**) arrow button to select **UTILITY**.
8. Press the **ENTER** button.
9. Press the up (**▲**) arrow button to select **CAL OVEN : SELECT**.
10. Press the right (**▶**) arrow button to access the **Gain Calibration** submenu.
11. Press the **ENTER** button twice and follow the prompts on the LCD display to calculate the gain value.

12. Wait approximately 20 seconds for the process to end.
13. Record the result in the test record.

NOTE. *If the value is outside the test limits, then the Oven is near the edge of the tune range and might need to be replaced.*

14. Press the **ENTER** button to return to the Calibration menu.
15. Press the **CANCEL** button to exit the Diagnostics menu.
16. Cycle the power to exit factory mode.

HD3G7 Module Performance Verification

The following procedures verify the functionality of the HD3G7 HD 3Gb/s SDI Video Generator module.

Required Equipment The following table lists the required equipment for the following procedure.

Table 77: Required equipment for HD3G7 performance verification

Item	No.	Minimum requirement	Recommended equipment
HD-SDI video signal generator	1	1080 59.94i 100% Color Bars signal output and embedded audio capabilities	Tektronix TG700 with HDVG7 generator module
Waveform monitor	1	HD-SDI waveform monitor with 3 Gb/s capabilities	Tektronix WFM7120 with Option 3G
Digital signal analyzer	1	Digital signal analyzer with a 20 GHz electrical sampling module and a probe interface module	Tektronix DSA8200 with an 80E04 electrical sampling module and an 80A03 Tek Connect Probe Interface module
Tekconnect 75 Ω to 50 Ω adapter with BNC input connector	1		Tektronix part number TCA75
Tekconnect adapter with BNC input connector	1		Tektronix part number TCA-BNC
20 m (75 ft) cable	1	Cable used to optimize WFM7120 equalizer operation	MarkerTek 1694-B-B-75
10 m, 20 m, 40 m, and 80 m cables or cable clone	1 each	Used in the Cable Accommodation and Converter Jitter Test	Standard Faraday HD Cable clone. Allows up to 150 m test. Consists of the following: FFC010A075 (10 m) FFC020A075 (20 m) FFC040A075 (40 m) FFC080A075 (80 m)
1 m (3 ft) BNC to BNC high-bandwidth cable	3	Used to hook DUT to scope for Amplitude and rise time tests	Belden 1694, MarkerTek 1694-B-B-3
Stable 10 kHz sine generator	1	CW sine wave, with 800 mV p-p \pm 5% into 75 Ω , THD < 60 dBc, 10 kHz, and less than 50 mV DC offset	A Tek AFG3101
Precision RMS voltmeter	1		Keithley 2700 DMM
6 dB SMA attenuator	1		Tektronix part number 015-1001-01
SMA (male) to BNC (female) adapter	1		Tektronix part number 015-0554-00
75 Ω Precision terminator	1		75 Ω Precision terminator (Tektronix part number 011-0102-03)
BNC to Banana Plug adapter	1		Pomona model 1269
BNC T	1		Tektronix part number 103-0030-00

Table 77: Required equipment for HD3G7 performance verification (cont.)

Item	No.	Minimum requirement	Recommended equipment
BNC (female) to BNC (female) 75 Ω barrel	1		Amphenol part number 31-70019
1 m (3 ft) 50 Ω cable	1		Tektronix part number 012-0057-01

Test Record

Photocopy this table and use it to record the performance test results.

Table 78: HD3G7 test record

Serial Number	Cal Date	Temperature	Humidity		
Step	Function Tested	Minimum	Maximum	Value	Value
1.	Initialization	Power on errors		Pass	Fail
		TG700 diagnostics		Pass	Fail
2.	HD3G7 diagnostics	Generator Flex1		Pass	Fail
		Generator DDS1		Pass	Fail
		Voltages		Pass	Fail
3.	Output function and jitter	Signal 1 1080 50p		Pass	Fail
		Jitter 1080 50p	0 UI	0.25 UI	
		Signal 2 1080 59.94p		Pass	Fail
		Jitter 1080 59.94p	0 UI	0.25 UI	
4.	Input function, cable accommodation and converter jitter	WFM7120 1080 60p		Pass	Fail
		Jitter readout	0 UI	0.25 UI	
		Jit lock		Pass	Fail
		cable length	80 m		

Table 78: HD3G7 test record (cont.)

Serial Number	Cal Date		Temperature	Humidity		
Step	Function Tested		Minimum	Maximum	Value	Value
5.	Amplitude characterization	DMM measurement (Typically, 0.2880 V)				
		Cycle RMS (Typically, 116 mV)				
		Cycle mean (Typically, 1 mV)				
		RMS amplitude of sine wave (Typically, 116 mV)	$\text{SQRT}((\text{cycle RMS})^2 - (\text{cycle mean})^2)$			
		Attenuation factor	2.35	2.55		
6.	SDI Output Amplitude	Signal 1 amplitude as measured (Typically, 328 mV)				
		Signal 1 amplitude calculated	776 mV	824 mV		
		Signal 2 amplitude as measured (Typically, 328 mV)				
		Signal 2 amplitude calculated	776 mV	824 mV		
7.	SDI Rise and Fall Time	Rise time	0 ps	135 ps		
		Fall time	0 ps	135 ps		
		Difference	-50 ps	+50 ps		
8.	Trigger Output Level	Trigger amplitude	648 mV	792 mV		

Procedures



WARNING. *Dangerous electric shock hazards exist inside the TG700 mainframe that can cause injury or death if the instrument is not handled properly. Only qualified service personnel should perform these procedures.*

Be sure you have performed the performance verification preparation before proceeding. (See page 35, *Performance Verification Preparation*.)

Performance verification procedures can be performed individually, if needed.

HD3G7 Diagnostics

Check the HD3G7 module Diagnostics before doing the performance verification tests:

1. Press the **MODULE** button to navigate to the **HD3G7** module.
2. Use the up (**▲**) or down (**▼**) arrow button to select **DIAGNOSTICS**.
3. Press the **ENTER** button.
4. Use the right (**▶**) arrow button to scroll through the diagnostics readings to view the **PLL STATUS** submenu.
5. Check that **Flex1** shows **Lock** and record Pass or Fail in the test record.
6. Use the right (**▶**) arrow button to view the **DDS STATUS** submenu.
7. Check that **DDS1 Phase** shows **Lock** and record Pass or Fail in the test record.
8. Use the right (**▶**) arrow button to view the voltage submenus, 1 through 4.
9. Check that all voltages show **OK** for each **VOLTAGE MON**, and record Pass or Fail in the test record.

NOTE. *It is common to see CRC errors after changing input connections or if there is no signal.*

10. Press the **CANCEL** button to exit the **DIAGNOSTICS** submenu.

Output Functional and Jitter Test

1. Connect a 20 m cable from the SIGNAL 1 output on the module to the 3G SDI A input of a WFM7120 with Option 3G.
2. Press the **MODULE** button on the TG700 to select **HD3G7: STATUS**.
3. Press the **FORMAT** button to view the **SELECT FORMAT** submenu.
4. Use the left (◀) or right (▶) arrow button to select a **1080 50p** format.
5. Press the **ENTER** button.
6. Check that the WFM7120 shows the 1080p 50 signal in the status bar on the display.
7. Record Pass or Fail in the test record.
8. Select a tile on the WFM7120 and press the **FULL** button to view the display full screen.
9. Press the **EYE** button on the WFM7120 and center the jitter waveform. If necessary, press and hold the **EYE** button to access the menu and set the jitter HP filter to 100 kHz.
10. Record the jitter shown on the jitter readout in the test record.
11. Repeat this procedure for the SIGNAL 2 output on the HD3G7 with a 1080 59.94p signal.

Input Functional, Cable Accommodation and Converter Jitter Test

1. Press the **MODULE** button on the TG700 to select **HDVG7: STATUS**.
2. Press the **FORMAT** button to view the **SELECT FORMAT** submenu.
3. Use the left (◀) or right (▶) arrow button to select a **1080 60i** signal.
4. Press the **ENTER** button.
5. Press the **COLOR BAR** button and select a 75% color bar signal.
6. Connect one end of a 1 m BNC cable to the HD3G7 HD SDI IN input. Connect the other end of the 1 m cable to a 75 Ω BNC to BNC barrel, and then another 1 m BNC cable to that. Finally, connect the end of that cable to the SIGNAL 1 output of the HDVG7.
7. Connect a cable from the SIGNAL 2 output on the HD3G7 to the 3G SDI A input on the WFM7120.
8. Press the **MODULE** button on the TG700 to select **HD3G7: STATUS**.
9. Press the **FORMAT** button to view the **SELECT FORMAT** submenu.
10. Use the left (◀) or right (▶) arrow button to select a **1080 60p** signal on the HD3G7 module.
11. Press the **ENTER** button.
12. Press the **CANCEL** button to exit the Format menu.

13. Press the **OTHER** button to enter converter mode. Allow a few seconds for the signal to stabilize before proceeding to the next step.
14. Check that the WFM7120 shows the 1080p 60 signal, with no errors, in the status bar on the display.
15. Record Pass or Fail in the test record.
16. Select a tile on the WFM7120 and press the **FULL** button to view the display full screen.
17. Press the **EYE** button on the WFM7120 and center the jitter waveform. If necessary, press and hold the **EYE** button to access the menu and set the jitter HP filter to 100 kHz.
18. Record the jitter shown on the jitter readout in the test record.
19. Connect an 80 m cable clone between the BNC to BNC barrel and a 1 m BNC cable setup that connects the HDVG7 SIGNAL 1 output and the HD3G7 HD SDI IN input.
20. Press the **CANCEL** button on the TG700 to exit the convertor mode menu.
21. Press the **MODULE** button to navigate to the **HD3G7** module.
22. Use the up (**▲**) or down (**▼**) arrow button to select **DIAGNOSTICS**.
23. Press the **ENTER** button.
24. Use the right (**▶**) arrow button to select **PLL STATUS**
25. Check that the **Jit** readout shows **Lock**.
26. Record Pass or Fail in the test record.
27. Use the right (**▶**) arrow button to select **CRC Errors**.

NOTE. *The Diagnostics menu includes an item that allows you to clear CRC errors from the log. It is common to see errors after changing input connections.*

28. If there are CRC errors, press the right (**▶**) arrow button to select **Clear CRC Errors**.
29. Press the **ENTER** button to clear the errors.
30. Press the left arrow button to return to the **CRC Errors** submenu and check that the number of errors is now zero.
31. Check that no CRC errors are detected for a period of 5 seconds.
32. Insert other cable clones to the 80 m clone to simulate increasing cable length in 10 m increments until EDH errors start to occur.

NOTE. *Errors may occur while you are connecting additional cables.*

33. Record the longest cable length that was error free for 5 seconds in the test record.

NOTE. *If there are no errors up to 150 m, record >150 m.*

Amplitude Characterization

There are two parts to this test: Part A and Part B. Part A sets up a reference to the DMM. Part B characterizes the test system.

Part A: Reference against the DMM.

1. Connect the equipment as follows:
 - a. One end of a 1 m high bandwidth cable to the AFG3101 output
 - b. The other end of the 1 m cable to the BNC T
 - c. The BNC T to a BNC to banana adapter
 - d. The other end of the BNC T to a precision terminator
 - e. The end of the banana adapter to the input of the DMM
2. Set the AFG3101 to output a sine wave into a load impedance of 75 Ω .
3. Set the AFG3101 to a 10 kHz output into a load impedance of 75 Ω .
4. Set the AFG3101 to a 800 mVp-p output into a load impedance of 75 Ω .
5. Check that the output of the AFG3101 is On.
6. Set the DMM to measure AC voltage using a medium filter setting. Set the range to allow for four digits of RMS amplitude.
7. Record the DMM measurement in the test record.

Set up the digital signal analyzer.



CAUTION. *Electrostatic discharge can damage the oscilloscope modules. To prevent damage, always work in a static free environment and discharge the static voltage from your body by wearing a grounded antistatic wrist strap while handling these modules.*

1. Install the 80A03 output cable into the Channel 1/2 slot of the oscilloscope.
2. Install the 80E04 sampling head into the 80A03 adapter and connect the two using the SMA cables.
3. Install the TCA-75 into the left port of the 80A03.
4. Install the TCA-BNC into the right port of the 80A03.
5. If needed, press the Default Settings button on the oscilloscope.
6. Press the Channel 1 button on the 80E04 sampling head to activate Channel 1.

Part B: Characterization of the test system.

1. Connect the equipment as follows:
 - a. AFG3101 output to 1 m high bandwidth cable
 - b. The other end of the cable to a TCA-75
 - c. The TCA-75 to the 80A03 in the oscilloscope and plug-in
 - d. A 50 Ω cable from the AFG3101 trigger output
 - e. The other end of the 50 Ω cable to the BNC to SMA adapter
 - f. The SMA adapter to the 6 dB pad
 - g. The 6 dB pad to the trigger direct input on the oscilloscope
2. Keep the AFG3101 at the same output as in Part A of this test.
3. Set the oscilloscope to a horizontal scale of 20 μ s.
4. Set the oscilloscope to a vertical scale of 50 mV.
5. Set the oscilloscope to averaging 16 and set the record length to 4000 points.
6. On the oscilloscope, select measurement 1 and then pulse amplitude and select it to measure Cycle RMS.
7. On the oscilloscope, select measurement 2 and then pulse amplitude and select it to measure Cycle Mean.
8. Record the Cycle RMS and Cycle Mean values in the test record.
9. Calculate the corrected RMS amplitude of the sine wave:
$$\text{SQRT}((\text{cycle RMS})^2 - (\text{cycle mean})^2)$$
10. Record the result in the test record.
11. Calculate the total attenuation factor for the system. This is the DMM measurement divided by the corrected RMS sine wave amplitude. This attenuation factor will be used after measuring the signal outputs in the next test.
12. Record the attenuation factor value in the test record.

SDI Output Amplitude

Perform this test with the instrument in factory mode. To put the instrument into factory mode, perform the following procedure:

Start up in factory mode.

1. At the same time, press the **MODULE**, **FORMAT**, and **FRONT PANEL ENABLE** buttons briefly, then continue to hold the **FRONT PANEL ENABLE** button until **TG700 Start up with factory mode** shows on the display.

NOTE. *The serial output level can be adjusted when the instrument is in factory mode. Be careful not to accidentally adjust this level, as this will invalidate the factory calibration. If you need to perform a serial output level adjustment, see the TG700 service manual for the procedure.*

SDI output amplitude procedure.

1. Connect a 50 Ω cable from the **TRIGGER OUTPUT** on the HD3G7 module (through the BNC to SMA adapter (with or without the 6 dB pad) to the trigger direct input on a sampling oscilloscope.
2. Connect a 1 m high bandwidth cable from the **SIGNAL 1** output of the module to the TCA75 BNC on the oscilloscope adapter.
3. Press the **MODULE** button until **HD3G7: STATUS** appears.
4. Use the up (**▲**) or down (**▼**) arrow button to select **CALIBRATION**.
5. Press the **ENTER** button.
6. Press the right (**►**) arrow button to select **20 Bits Square**.
7. Press the **ENTER** button.
8. Set the scope to averaging 16 and set the record length to 4000 points, the time/div to 2 ns, and the amplitude per division to 50 mV.
9. On the scope, select Measurement 3, Pulse-Amplitude, and then Amplitude to measure the amplitude on the flat part of the long pulse.

10. Right click on the measurement readout, and select **Show Statistics** from the pop-up menu.
11. Press the **Clear Data** button on the oscilloscope and wait about 5 seconds before proceeding to the next step.
12. Record the average value, which is indicated by the letter μ . Multiply μ by the attenuation factor you obtained in the previous test.
13. Record the result in the test record.
14. Repeat this procedure for the SIGNAL 2 output on the HD3G7.

NOTE. *To ensure SDI signal lock, cycle the power on the TG700 after completing performance verification procedures in factory mode.*

SDI Rise and Fall Time

Perform this procedure with the instrument in factory mode. (See page 152, *Start up in factory mode.*)

1. Connect a 50 Ω cable from the **TRIGGER OUTPUT** on the HD3G7 module through the SMA to BNC adapter (with or without the 6 dB pad) to the trigger direct input on a sampling oscilloscope.
2. Connect a cable from the **SIGNAL 1** output of the module to the TCA75 BNC on the oscilloscope adapter.
3. Press the **MODULE** button until **HD3G7: STATUS** appears.
4. Use the up (**▲**) or down (**▼**) arrow button to select **CALIBRATION**.
5. Press the **ENTER** button.
6. Press the right (**▶**) arrow button to select **20 Bits Square**.
7. Press the **ENTER** button.
8. On the oscilloscope, set the horizontal scale to 200 ps.
9. Set the horizontal position to put the rising edge of the waveform about 2.5 divisions to the left of center.
10. Set the oscilloscope to averaging 16 and set the record length to 4000 points.
11. On the oscilloscope, select Measurement 4 and then Pulse-Timing for the Rise Time.
12. Select Measurement 5 and then Pulse-Timing for the Fall Time.
13. Select the Reference Level tab from Measure and set the reference high to 80% and the low to 20%.
14. Measure the rise time and record the result in the test record.
15. Use the horizontal position knob to put the falling edge about 2.5 divisions left of center.
16. Measure the fall time and record the result in the test record.
17. Check that the difference between the rise and fall times is within the specified limits and record the result in the test record.
18. Repeat this procedure for the **SIGNAL 2** output on the HD3G7.

Trigger Output Level

Perform this procedure with the instrument in factory mode. (See page 152, *Start up in factory mode.*)

1. Connect a cable from the **SIGNAL 1** output on the HD3G7 module through the SMA to BNC adapter (with or without the 6 dB pad) to the trigger direct input on a sampling oscilloscope.
2. Connect a 50 Ω cable from the **TRIGGER OUTPUT** of the module to the TCA-BNC on the oscilloscope adapter.
3. Check that Channel 2 of the oscilloscope is on and that C2 is selected as the active channel.
4. Press the **MODULE** button until **HD3G7: STATUS** appears.
5. Use the up (**▲**) or down (**▼**) arrow button to select **CALIBRATION**.
6. Press the **ENTER** button.
7. Press the right (**►**) arrow button to select **20 Bits Square**.
8. Press the **ENTER** button.
9. Set the oscilloscope to averaging 16 and set the record length to 4000 points, the time/div to 2 ns, and the amplitude per division to 100 mV.
10. On the oscilloscope, select Measurement 6 and set it to the channel that has the TCA-BNC.
11. On the oscilloscope, select Measure > Pulse-Amplitude > Amplitude to measure the trigger.
12. Record the results in the test record.

HDLG7 Module Performance Verification

The following procedures verify the functionality of the HDLG7 HD Dual Link Generator module.

Required Equipment The following table lists the required equipment for the following procedure.

Table 79: Required equipment for HDLG7 performance verification

Item	No.	Minimum requirement	Recommended equipment
HD-SDI video signal generator	1	1080 59.94i 100% Color Bars signal output and embedded audio capabilities	Tektronix TG700 with HDVG7 generator module
HD waveform monitor	1	HD-SDI waveform monitor with eye measurement capabilities	Tektronix WFM7100 Option PHY
75 Ω BNC cable	3	General purpose digital video male-to-male BNC connectors, 1 or 2 m long	Belden 9281 or Tektronix part number 012-0159-01
75 Ω coaxial terminator	3	Male connector, precision	Tektronix part number 011-0102-03

Test Record Photocopy this table and use it to record the performance test results.

Table 80: HDLG7 test record

Serial Number	Cal Date	Temperature	Humidity		
Step	Function Tested	Minimum	Cal Data	Maximum	
1.	Serial Output Amplitude	Link A (top BNC)	720 mV	mV	880 mV
		Link A (bottom BNC)	720 mV	mV	880 mV
		Link B (top BNC)	720 mV	mV	880 mV
		Link B (bottom BNC)	720 mV	mV	880 mV
2.	Serial Output Rise Time (20% to 80% amplitude points)	Link A (top BNC)		ps	270 ps
		Link A (bottom BNC)		ps	270 ps
		Link B (top BNC)		ps	270 ps
		Link B (bottom BNC)		ps	270 ps

Table 80: HDLG7 test record (cont.)

Serial Number	Cal Date	Temperature	Humidity	
Step	Function Tested	Minimum	Cal Data	Maximum
3.	Serial Output Fall Time (20% to 80% amplitude points)	Link A (top BNC)	ps	270 ps
		Link A (bottom BNC)	ps	270 ps
		Link B (top BNC)	ps	270 ps
		Link B (bottom BNC)	ps	270 ps

Procedures The following procedure determines if the HDLG7 HD Dual Link Generator module is operating correctly.

Be sure you have performed the performance verification preparation before proceeding. (See page 35, *Performance Verification*.)



WARNING. *Dangerous electric shock hazards exist inside the TG700 mainframe. Only qualified service personnel should perform these procedures.*

Serial Digital Video Outputs. This test verifies that serial digital signals are output correctly from the LINK A and LINK B connectors. The following equipment is required for the test:

- HD waveform monitor
- 75 Ω BNC cable
- 75 Ω coaxial terminator

Perform the following procedure to verify that serial digital signals are output correctly from the LINK A and LINK B connectors.

1. Use the 75 Ω BNC cable to connect the upper LINK A connector on the HDLG7 module to the SDI A input on the HD waveform monitor as shown in the following figure.
2. Use the 75 Ω coaxial terminator to terminate the lower LINK A connector on the HDLG7 module as shown in the following figure.

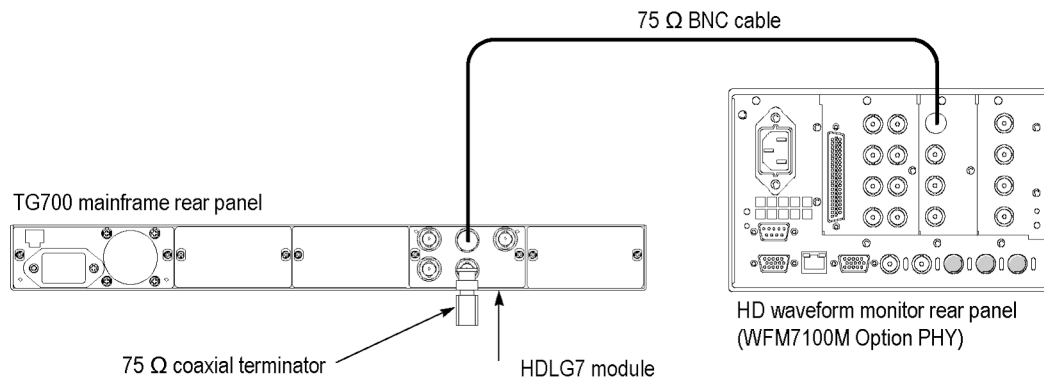

Figure 28: Equipment connections for verifying the serial digital video outputs

3. Recall the Factory Default preset as follows:
 - a. Press the **MODULE** button to display the TG700 main menu.
 - b. Press the up (**▲**) or down (**▼**) arrow button to select **RECALL**.
 - c. Press the left (**◀**) or right (**▶**) arrow button to select **Factory Default**.
 - d. Press **ENTER** to recall the factory default settings.
4. Select the **100% Color Bars** signal as follows:
 - a. Press the **MODULE** button to display the HDLG7 main menu.
 - b. Press the **COLOR BAR** test signal button until the **100% Color Bars** signal is selected.
5. Select the **1080 59.94p** format as follows:
 - a. Press the **FORMAT** button.
 - b. Press the left (**◀**) or right (**▶**) arrow button to select **1080 59.94p**, and then press **ENTER**.
 - c. Press the **CANCEL** button to return to the module main menu.
6. Set the HD waveform monitor to take Eye measurements.
7. Verify the eye amplitude and rise and fall times values are as follows:

Eye amplitude: 720 mV to 880 mV

Rise and fall time (20% to 80%): < 270 ps
8. Change the BNC cable connection from the upper LINK A connector to the lower LINK A connector and change the 75 Ω coaxial terminator from the lower LINK A connector to the upper LINK A connector.
9. Repeat step 7.

10. Change the BNC cable connection from the lower LINK A connector to the upper LINK B connector and change the 75 Ω coaxial terminator from the upper LINK A connector to the lower LINK B connector.
11. Repeat step 7.
12. Change the BNC cable connection from the upper LINK B connector to the lower LINK B connector and change the 75 Ω coaxial terminator from the lower LINK B connector to the upper LINK B connector.
13. Repeat step 7.

This completes the HDLG7 module performance verification procedure. If you require further assistance, contact your nearest Tektronix Service Center.

HDVG7 Module Performance Verification

The following procedures verify the functionality of the HDVG7 HDTV Video Generator module.

Required Equipment The following table lists the required equipment for the following procedure.

Table 81: Required equipment for HDVG7 performance verification

Item	No.	Minimum requirement	Recommended equipment
Digital television waveform monitor	1		Tektronix WFM1125 Option 0D
HDTV picture monitor	1		Sony HDM1220J
Digital audio monitor	1		Tektronix 764
Sampling oscilloscope	1	Bandwidth: 6 GHz or higher	Tektronix TDS820
75 Ω BNC cable	5	Length: 42 inches	Tektronix part number 012-0074-00
50 Ω BNC to SMA adapter	1		Tektronix part number 015-1018-00
75 Ω coaxial terminator	5		Tektronix part number 011-0102-01
75 Ω signal adapter	1	Bandwidth: 1 GHz	Tektronix AMT75

Test Record Photocopy this table and use it to record the performance test results.

Table 82: HDVG7 test record

Serial Number	Cal Date		Temperature	Humidity	
Step	Function Tested		Minimum	Cal Data	Maximum
1.	Serial Output Amplitude	SIGNAL 1 (Typical value: 800 mV)	_____	mV	_____
		SIGNAL 2 (Typical value: 800 mV)	_____	mV	_____
2.	Serial Output Rise Time (20% to 80% amplitude points)	SIGNAL 1		ps	270 ps
		SIGNAL 2		ps	270 ps
3.	Serial Output Fall Time (20% to 80% amplitude points)	SIGNAL 1		ps	270 ps
		SIGNAL 2		ps	270 ps
Option BK					
4.	Serial Output Amplitude	BLACK 1 (Typical value: 800 mV)	_____	mV	_____
		BLACK 2 (Typical value: 800 mV)	_____	mV	_____
5.	Serial Output Rise Time (20% to 80% amplitude points)	BLACK 1		ps	270 ps
		BLACK 2		ps	270 ps
6.	Serial Output Fall Time (20% to 80% amplitude points)	BLACK 1		ps	270 ps
		BLACK 2		ps	270 ps

Procedures

The following procedure determines if the HDVG7 HDTV Video Generator module is operating correctly.

Be sure you have performed the performance verification preparation before proceeding. (See page 35, *Performance Verification*.)



WARNING. *Dangerous electric shock hazards exist inside the TG700 mainframe. Only qualified service personnel should perform these procedures.*

Serial Digital Outputs. This test verifies that serial digital signals are output correctly from the SIGNAL 1 and SIGNAL 2 connectors. The following equipment is required for the test:

- Digital TV waveform monitor
- HDTV picture monitor
- Digital audio monitor
- Five 75 Ω BNC cables
- Five 75 Ω coaxial terminators

Perform the following procedure to verify that serial digital signals are output correctly from the SIGNAL 1 and SIGNAL 2 connectors.

1. Use the 75 Ω BNC cable to connect SIGNAL 1 connector on the HDVG7 Generator module to the CHA connector on the digital TV waveform monitor rear panel as shown in the following figure. (See Figure 27.)
2. Use the 75 Ω coaxial terminator to terminate the SIGNAL 2 connector on the HDVG7 Generator module.
3. Use the 75 Ω BNC cables to connect Pr, Pb, and Y ANALOG OUT connectors on the digital TV waveform monitor rear panel to INPUT A R/P_R, B/P_B, G/Y connectors, respectively, on the HDTV picture monitor rear panel as shown in the following figure. (See Figure 27.)
4. Use the 75 Ω coaxial terminators to terminate the other loop through to R/P_R, B/P_B, and G/Y connectors on the HDTV picture monitor rear panel.
5. Use the 75 Ω BNC cable to connect AUDIO CHA connector on the digital TV waveform monitor rear panel to CH1-2 BNC connector on the digital audio monitor rear panel as shown in the following figure. (See Figure 27.)
6. Use the 75 Ω coaxial terminator to terminate the other loop through to CH1-2 BNC connector on the digital audio monitor rear panel.

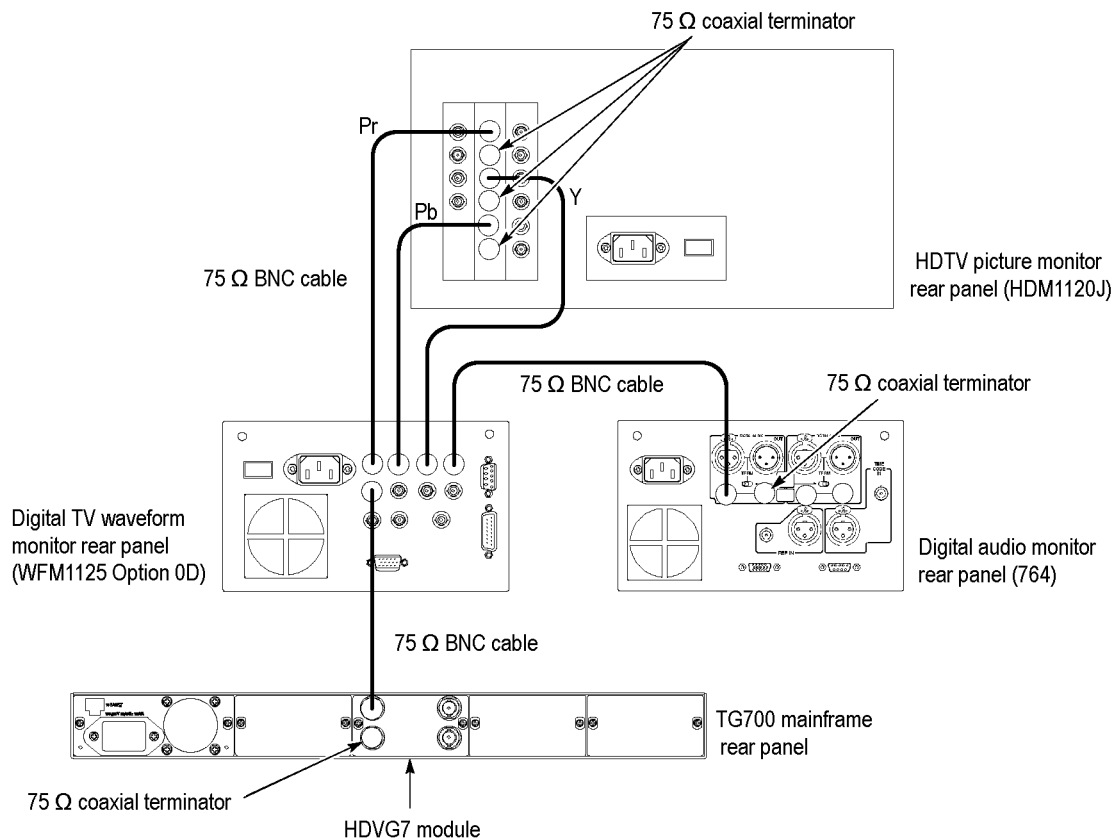

Figure 29: Equipment connections for verifying the serial digital outputs

7. Set the digital TV waveform monitor settings as follows:

Control	Setting
Input	CH A
Display	Parade
Format	240M/274M
Interlaced/Progressive	Interlaced

8. Recall the Factory Default preset as follows:

- a. Press the **MODULE** button to display the TG700 main menu.
- b. Press the up (▲) or down (▼) arrow button to select **RECALL**.
- c. Press the left (◀) or right (▶) arrow button to select **Factory Default**.
- d. Press **ENTER** to recall the factory default settings.

9. Select the **75% Color Bars** signal as follows:

- a. Press the **MODULE** button to display the HDVG7 main menu.

- b. Press the **COLOR BAR** test signal button until the **75% Color Bars** signal is selected.
10. Turn on the circle overlay as follows:
 - a. Press the **CANCEL** button.
 - b. Press the up (▲) or down (▼) arrow button to select **OVERLAY**, and then press **ENTER**.
 - c. Press the left (◀) or right (▶) arrow button to select **Circle**, and then press **ENTER** to access the **CIRCLE OVERLAY** submenu.
 - d. Press the left (◀) or right (▶) arrow button to select **Enable**, and then press **ENTER**.
11. Turn on the embedded audio for Group 1 as follows:
 - a. Press the **CANCEL** button to return the module main menu.
 - b. Press the up (▲) or down (▼) arrow button to select **AUDIO (EMBEDDED)**.
 - c. Press the left (◀) or right (▶) arrow button to select **Group 1**, and then press **ENTER** to access the **AUDIO GROUP** submenu.
 - d. Press the left (◀) or right (▶) arrow button to select **Enable**, and then press **ENTER**.
 - e. Press the **CANCEL** button to return the module main menu.
12. Check the displayed waveform and CRC error:
 - a. Verify that the waveform and the overlay circle are correctly displayed on the digital TV waveform monitor.
 - b. Verify that the **CRC ERROR LED** on the digital TV waveform monitor does not light.
13. Check the embedded audio:
 - a. On the digital audio monitor front panel, press the **MENU** button to display the menu.
 - b. Select the **Input** item from the menu, and select **CH1-2 input: BNC-unbalanced** item from the submenu.
 - c. On the digital audio monitor front panel, press the **CLEAR** button to clear the menu.
 - d. On the digital audio monitor front panel, press the **CH STATUS** button to display **CHANNEL STATUS** view.
 - e. In the view, check that CRC errors are not displayed.
 - f. On the digital audio monitor front panel, press the **Audio View** button.

- g.** Verify that the digital audio monitor bar graphs show both Channel 1 and Channel 2 at -20 dBfs.
- 14.** Check that the correct color bar and the overlay text are displayed on the HDTV picture monitor.
- 15.** Change the BNC cable connection from the SIGNAL 1 connector to the SIGNAL 2 connector and change the $75\ \Omega$ terminator from the SIGNAL 2 connector to the SIGNAL 1 connector on the HDVG7 Generator module.
- 16.** Repeat steps 12 through 14.

Serial Digital Black Outputs (Option BK Only). This test verifies that serial digital black signals are output correctly from the BLACK 1 and BLACK 2 connectors.

17. Change the BNC cable connection from the SIGNAL 2 connector to the BLACK 1 connector and change the 75 Ω terminator from the SIGNAL 1 connector to the BLACK 2 connector on the HDVG7 Generator module.
18. Select the **40% Flat Field** signal as follows:
 - a. Press the **CANCEL** button to return the module main menu.
 - b. Press the up (**▲**) or down (**▼**) arrow button to select **BLACK (OPTION)**.
 - c. Press **ENTER** to access the BLACK submenu.
 - d. Press the up (**▲**) or down (**▼**) arrow button to select **SIGNAL**.
 - e. Press the left (**◀**) or right (**▶**) arrow button to select **40% Flat Field**, and then press **ENTER**.
19. Turn on the embedded audio for Group 1 as follows:
 - a. Press the **CANCEL** button to return the BLACK submenu.
 - b. Press the up (**▲**) or down (**▼**) arrow button to select **AUDIO (EMBEDDED)**.
 - c. Press the left (**◀**) or right (**▶**) arrow button to select **Group 1**, and then press **ENTER** to access the AUDIO GROUP submenu.
 - d. Press the left (**◀**) or right (**▶**) arrow button to select **Enable**, and then press **ENTER**.
 - e. Press the **CANCEL** button to return the BLACK submenu.
20. Verify that the waveform is correctly displayed on the digital TV waveform monitor.
21. Verify that the CRC ERROR LED on the digital TV waveform monitor does not light.
22. Verify that the digital audio monitor bar graphs show both Channel 1 and Channel 2 at -20 dBfs.
23. Verify that the correct flat field signal is displayed on the HDTV picture monitor.
24. Change the BNC cable connection from BLACK 1 connector to the BLACK 2 connector and change the 75 Ω terminator from BLACK 2 connector to the BLACK 1 connector on the HDVG7 Generator module.
25. Repeat steps 20 through 23.

Eye Pattern Check.

This test verifies the signal level and eye pattern of the SIGNAL 1 and SIGNAL 2 outputs. The following equipment is required for the test:

- Sampling oscilloscope
- 75 Ω signal adapter (AMT75)
- 75 Ω BNC cable
- SMA-to-BNC adapter
- 75 Ω coaxial terminator

Perform the following procedure to verify the signal level and eye pattern of the SIGNAL 1 and SIGNAL 2 outputs.

1. Use the 75 Ω BNC cable, 75 Ω signal adapter, and SMA-to-BNC adapter to connect the SIGNAL 1 connector on the HDVG7 Generator module to the CH1 input connector on the oscilloscope as shown in the following figure.

NOTE. *Some sampling oscilloscopes do not automatically adjust their readouts to account for the $\div 5$ attenuation of the AMT75. You must remember to account for this attenuation while viewing the oscilloscope readouts if you are using an oscilloscope of this type.*

2. Use the 75 Ω coaxial terminator to terminate the SIGNAL 2 connector on the HDVG7 Generator module.
3. Set the sampling oscilloscope settings as follows:

Control	Setting
Vertical	30 mV/div
Horizontal	200 ps/div
Main Position	700 ps
Trig Source	CH1
Trig Level	0 V
Trig Slope	Rising Edge
Acquire Menu	Normal
DISPLAY	Variable persistence: 500 ms
Measure	Amplitude

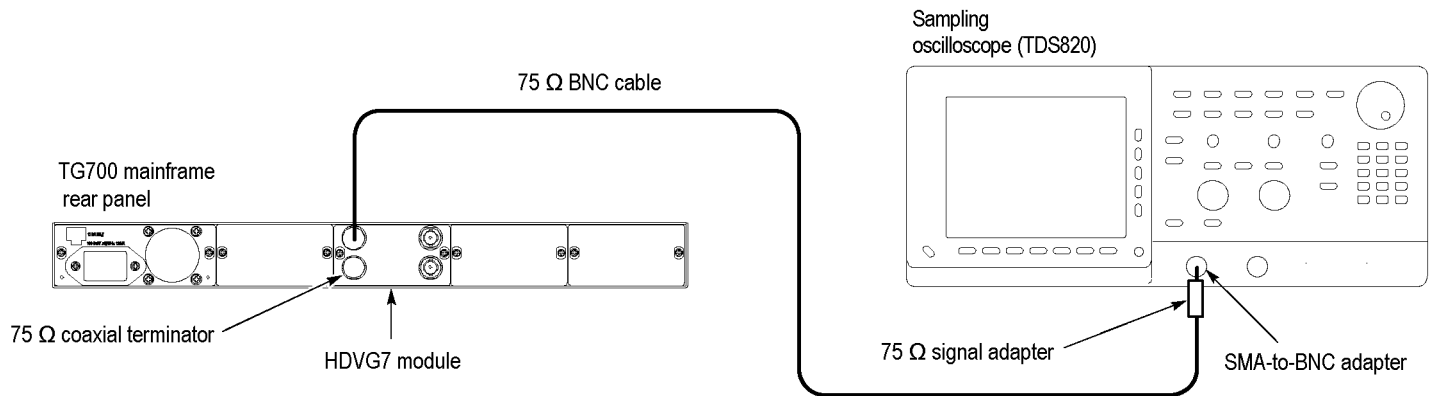

Figure 30: Equipment connection for verifying the output level and eye pattern

- Verify that SIGNAL 1 eye pattern displayed on the sampling oscilloscope is fully open. The following figure shows an example of the eye pattern for an acceptable output signal.

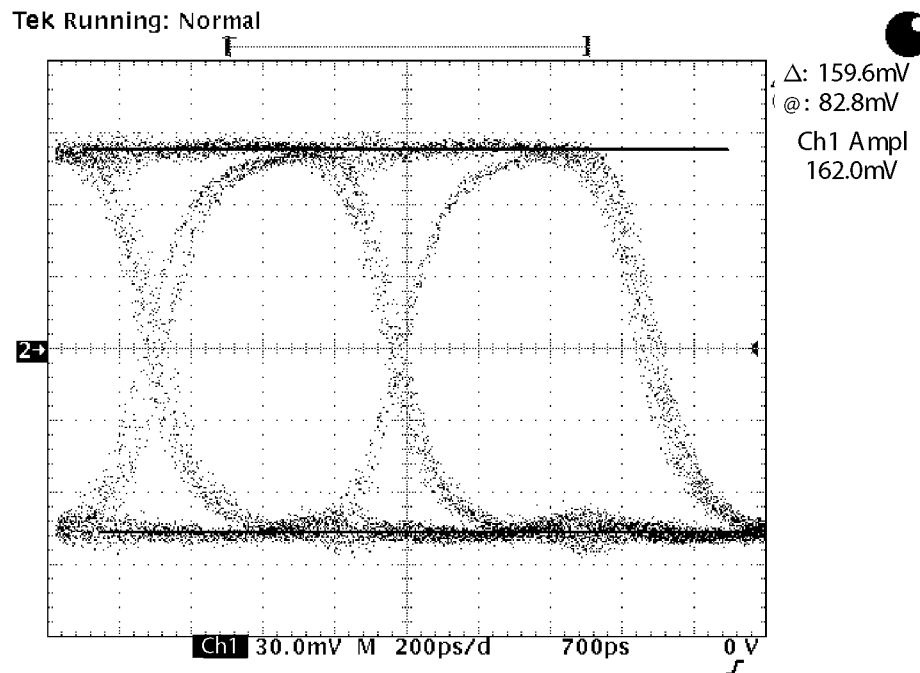

Figure 31: Example of eye pattern for an acceptable output signal

- Use the sampling oscilloscope to measure that the amplitude, rise and fall time are as follows:
Amplitude: approximately 160 mV Rise and fall time: t 270 ps (20% to 80%)
- Change the BNC cable connection from the SIGNAL 1 connector to the SIGNAL 2 connector and change the 75 Ω terminator from the SIGNAL 2 connector to the SIGNAL 1 connector on the HDVG7 Generator module.

7. Check that SIGNAL 2 eye pattern displayed on the sampling oscilloscope is fully open. (See Figure 31.)
8. Repeat step 5.

BLACK Output Eye Pattern Check (Option BK Only). This test verifies the signal level and eye pattern of the BLACK 1 and BLACK 2 outputs.

9. Change the BNC cable connection from the SIGNAL 2 connector to the BLACK 1 connector and change the 75 Ω terminator from the SIGNAL 1 connector to the BLACK 2 connector on the HDVG7 Generator module.
10. Check that BLACK 1 eye pattern displayed on the sampling oscilloscope is fully open. (See Figure 31.)
11. Repeat step 5.
12. Change the BNC cable connection from the BLACK 1 connector to the BLACK 2 connector and change the 75 Ω terminator from the BLACK 2 connector to the BLACK 1 connector on the HDVG7 Generator module.
13. Check that SIGNAL 2 eye pattern displayed on the sampling oscilloscope is fully open. (See Figure 31.)
14. Repeat step 5.

This completes the HDVG7 module performance verification procedure. If you require further assistance, contact your nearest Tektronix Service Center.